

Venta V241

Two-way Globe Valve, Bronze, PN 16



Product Description

The V241 is a precision flow control valve with polished stainless steel seats for a strong close off and a low leakage rate for all heating, cooling, air handling and domestic hot water systems.

The patented crown plug design provides an excellent low flow control and is self-cleaning when used in media with a high concentration of dirt particulates.

Resilient construction materials allow the valve to be used at high differential pressures and with the following types of media.

- Hot and chilled water.
- Water containing phosphate or hydrazine additives.
- Water with antifreeze additives such as glycol.

Specifications

Design	Two-way globe valve
Pressure class	PN 16
Flow characteristic	EQM
Stroke	20 mm
Rangeability Kvs/Kv _{min}	see table
Leakage	Up to 0,02% of Kvs
ΔPm	600 kPa, water
Max. temperature of medium	150 °C
Min. temperature of medium ^a	-20 °C
End Connections	External pipe thread according to ISO 228/1
Connection sets	see tables
Materials	
Body	Bronze Rg5
Plug and seat	Stainless steel SS 2346
Stem	Stainless steel SS 2346
Pressure Equipment Directive	PED 2014/68/EU, Article 4 (3)

a. If the valve is used for media at temperatures below 0 °C, it should be equipped with a stem heater in order to prevent ice formation on the valve stem.

Available Part Numbers

DN	Size		Kvs m ³ /h	Part number (excluding connection)	Rangeability
	in.				
15	½"		0.25	721 4106 000	> 50
15	½"		0.40	721 4110 000	
15	½"		0.63	721 4114 000	
15	½"		1.0	721 4118 000	
15	½"		1.6	721 4122 000	
15	½"		2.5	721 4126 000	
15	½"		4.0	721 4130 000	
20	¾"		6.3	721 4134 000	> 100
25	1"		10	721 4138 000	
32	1¼"		16	721 4142 000	
40	1½"		25	721 4146 000	
50	2"		38	721 4150 000	

End Connection Accessories ordered separately, pg. 5.

Spare Parts

Description	Part No.
Stuffing box Standard type S max 150 °C	1 001 0800 0

Key to Technical specification

- Rangeability is the ratio of Kvs and Kv_{min}
- Kvs is the flow through the valve in m³/h at the specified valve lift and at a pressure drop of 100 kPa across the valve.
- Kv_{min} is the minimum controllable flow (m³/h) at a pressure drop of 100 kPa within the range in which the valve characteristics conform to the slope requirements of EN60534-1

Design and Characteristics

The patented plug design of the V241 gives good resistance against solid particles in the fluid.

The plug is guided throughout the lift, which reduces the risk for vibrations. The valve closes with the stem up.

The V241 has a metal to metal seat constructed from polished Stainless steel for a resilient and low leakage close off performance.

The flow characteristics of the V241 is equal percentage modified. This characteristic makes it possible to control low flow rates down to almost closed position. This is particularly important for achieving good control performance in systems with wide load variations.

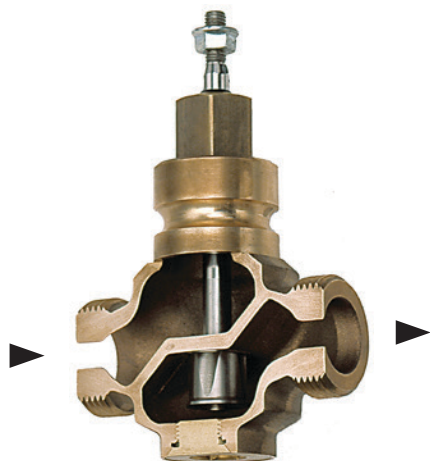

Flow Characteristics Chart

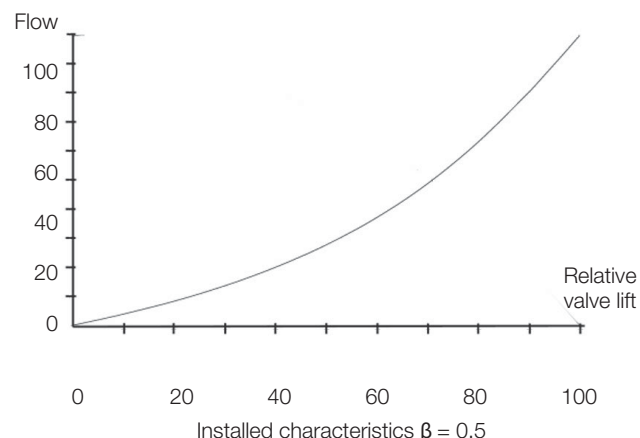

Cavitation

Cavitation takes place in a valve when the velocity of the fluid media over the plug and seat increases to such an extent that gas bubbles are created.

As the fluid passes over the seat and the velocity decreases, these gas bubbles collapse (implode), generating considerable noise and erosion to the valve trim.

The cavitation diagram provides guidance as to the cavitation zone where this phenomae will exist.

Chart usage:

- Using the static pressure before the valve (e.g. 1000 kPa), plot the horizontal line to the line for the temperature of the liquid (e.g. 120 °C).
- From the intersection point, plot a vertical line downwards and read off the max.permissible pressure drop across the valve.
- If the computed pressure drop exceeds the value from the diagram there is risk for cavitation.

Pressure drop chart at the beginning of Cavitation

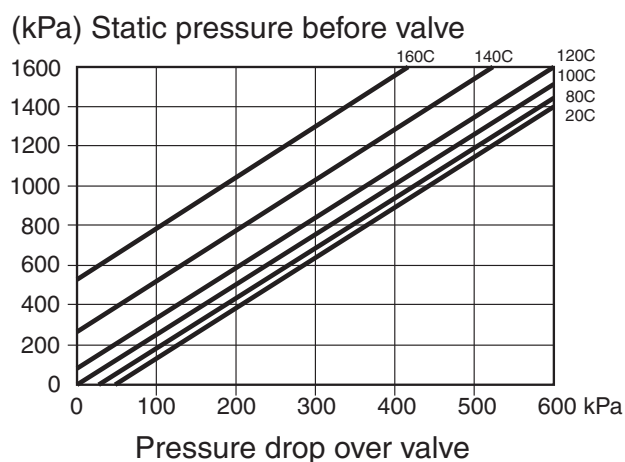

Actuator Selection

Use the diagram below to select actuator for the V241 to close required ΔP_c .

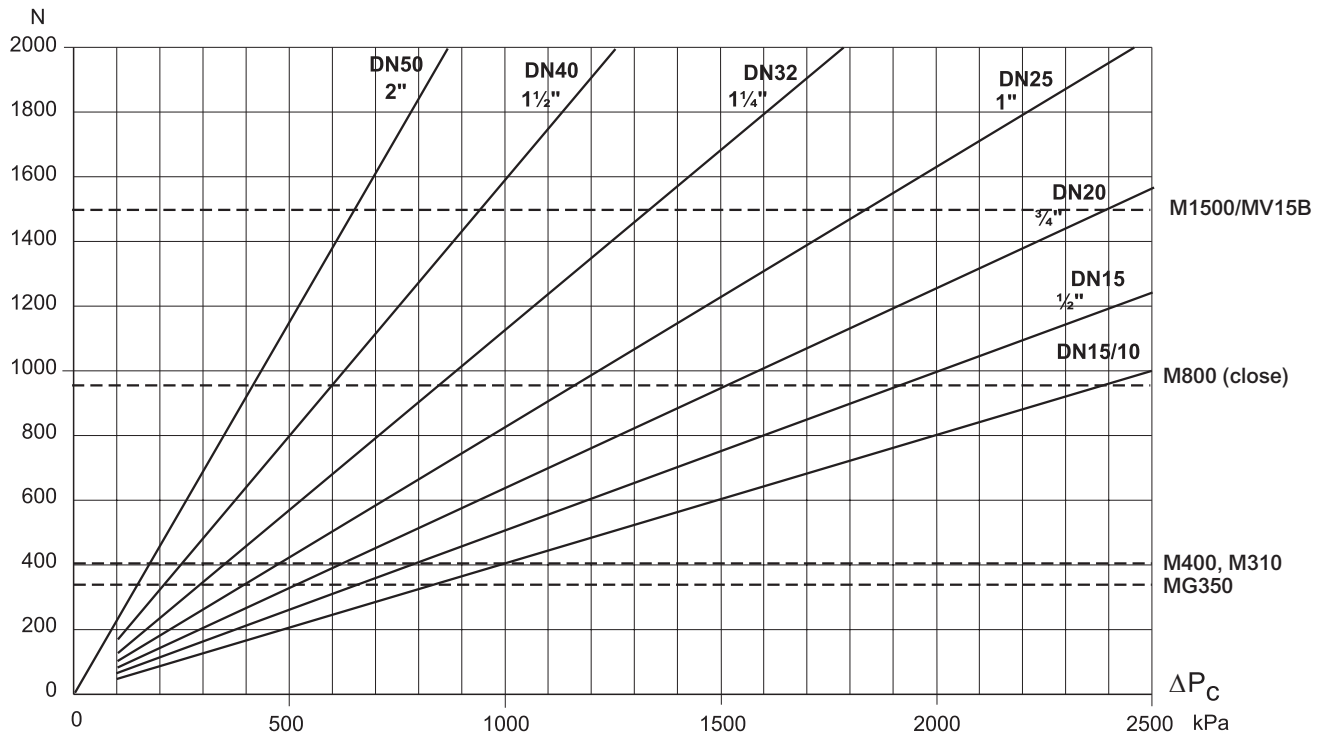

Installation

The valve should be mounted with flow direction in accordance with the valve marking. It is recommended to install the valve in the return pipe, in order to avoid exposing the actuator to high temperatures. The valve must not be installed with the actuator mounted below the valve. To ensure that suspended solids will not become jammed between the valve plug and seat, a filter should be installed upstream of the valve, and the pipe system should be flushed before the valve is installed.

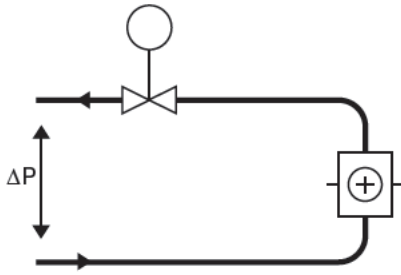

A. Typical installation without local circulating pump.

To provide a good function, the pressure drop across the valve should be no less than half of the available pressure (ΔP). This corresponds to a valve authority of 50%.

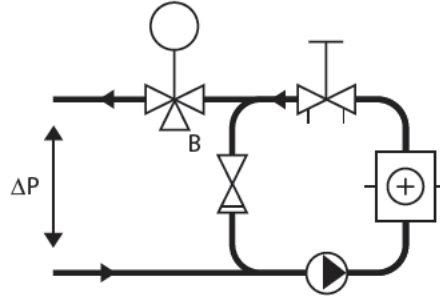

B. Typical installation with local circulating pump.

To provide a good function, the Kvs value of the valve is to be selected so that the entire available pressure drop (ΔP) falls across the control valve.

Pressure Drop Chart

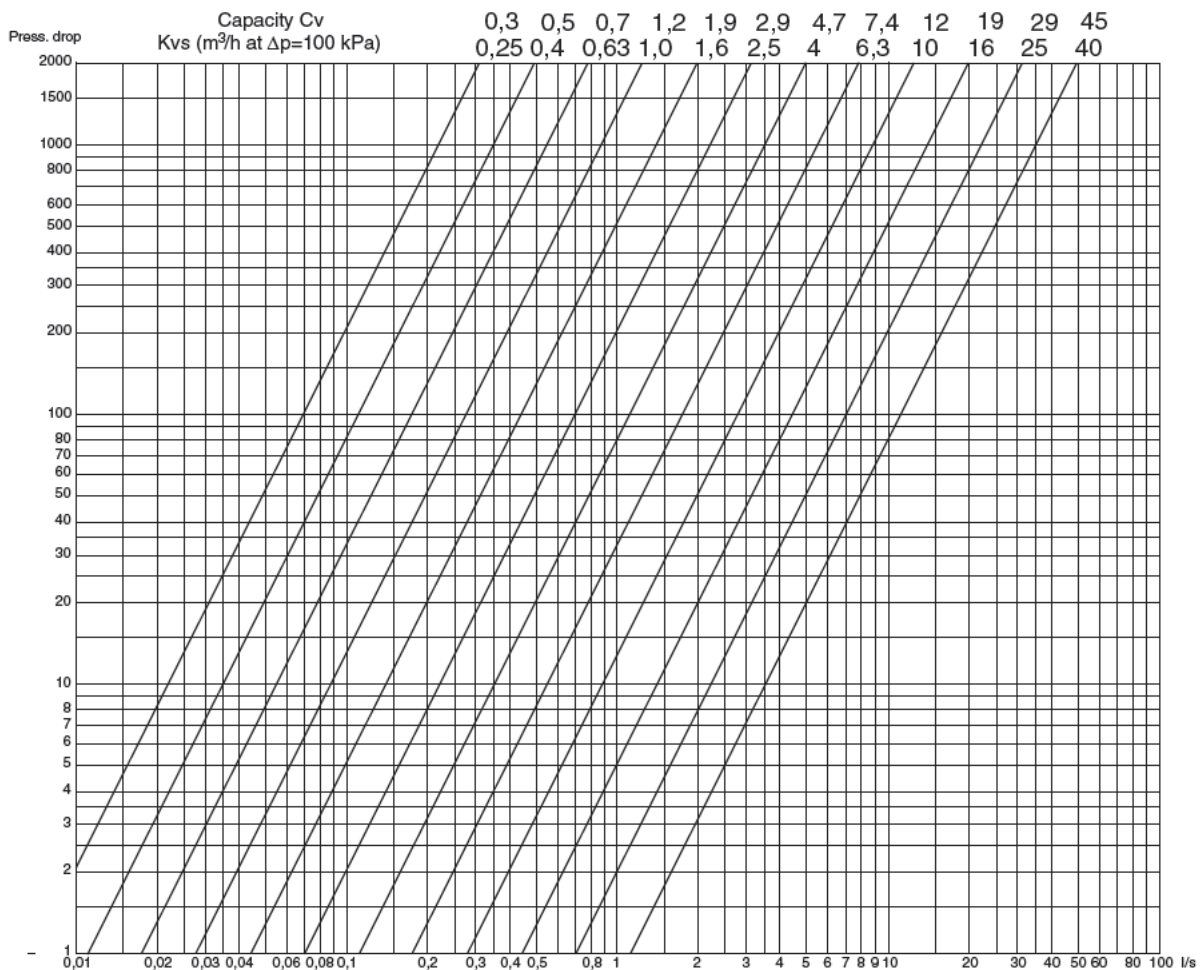

End Connection Accessories

Internal Thread Connection

Valve Size	Int. thread	AA1	Part No. for connection, one pkg./port	
DN	$\varnothing d1^*$	mm	w/Packing, std	w/Packing, spec.**
15	R 1/2"	146	911 2100 015	911 2103 015
20	R 3/4"	146	911 2100 020	911 2103 020
25	R 1"	159	911 2100 025	911 2103 025
32	R 1 1/4"	169	911 2100 032	911 2103 032
40	R 1 1/2"	197	911 2100 040	911 2103 040
50	R 2"	222	911 2100 050	911 2103 050

* Thread according to ISO 7/1

** The accessory combination "w/Packing, special" is intended for the primary circuit of district heating connections.

Materials

Union nut malleable iron casting, galv.
Union end malleable iron casting, galv.

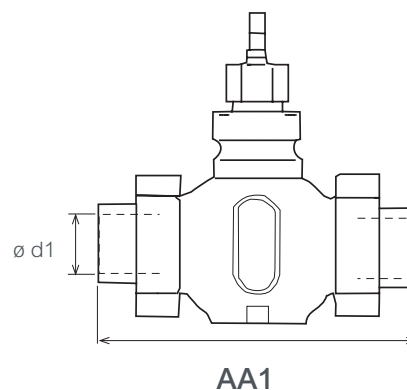

Packing, standard
or Packing, spec

Klingersil C4400
Klingersil Top chem
1,5 mm

Soldering Type Connection

Valve Size	$\varnothing d2$	AA2	Part No. for connection, one pkg./port	
DN	mm		w/Packing, std	w/Packing, spec.*
15	15	136	911 2101 015	911 2104 015
20	22	146	911 2101 020	911 2104 020
25	28	155	911 2101 025	911 2104 025
32	35	163	911 2101 032	911 2104 032
40	42	200	911 2101 040	911 2104 040
50	54	232	911 2101 050	911 2104 050

* The accessory combination "w/Packing, special" is intended for the primary circuit of district heating connections.

Materials

Union nut malleable iron casting, galv.
Union end Bronze, Stainless steel SS 5204

Packing, standard Klingersil C4400
or Packing, spec Klingersil Top chem
1,5 mm

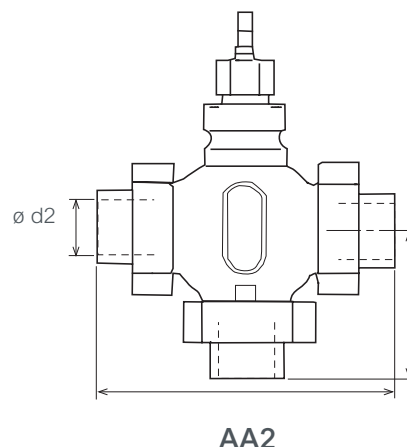

Welded Type Connection

Valve Size	$\varnothing d3$	AA3	Part No. for connection, one pkg./port	
DN	mm		w/Packing, std	w/Packing, spec.*
15	21.3	182	911 2102 015	911 2105 015 1)
20	26.9	182	911 2102 020	911 2105 020 1)
25	33.7	187	911 2102 025	911 2105 025 1)
32	42.4	197	911 2102 032	911 2105 032 1)
40	48.3	232	911 2102 040	911 2105 040
50	60.3	262	911 2102 050	911 2105 050

1) Material Union nut: Brass SS 5252

* The accessory combination "w/Packing, special" is intended for the primary circuit of district heating connections.

Materials

Union nut malleable iron casting, galv. (except 1)
Union end Stainless Steel SS 2172, SS 2174

Packing, standard Klingersil C4400
or Packing, spec Klingersil Top chem
1,5 mm

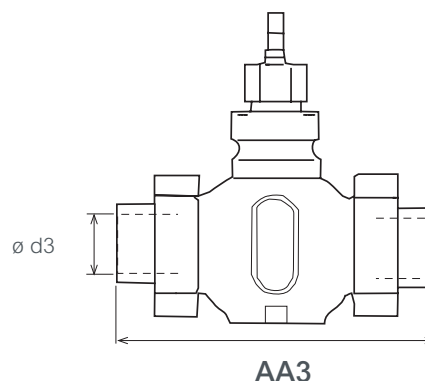

Dimensions And Weight

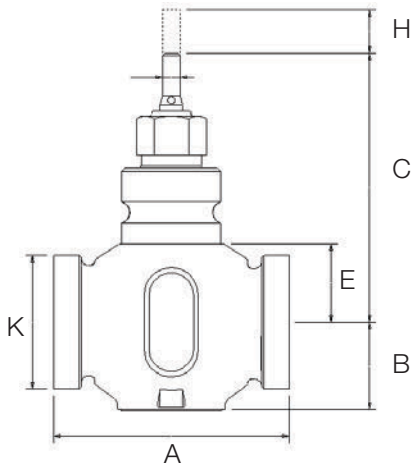

Valve Size DN	Dimensions (mm)					K	Weigh kg
	A	B	C	E	H		
15	100	36	109.5	23.5	20	25	1.0
20	100	38	116	30	20	32	1.2
25	105	39	120	34	20	38	1.4
32	105	39	121	35	20	50	1.8
40	130	48.5	128.5	42.5	20	57	2.6
50	150	58	139	53	20	70	4.3