



ALCM-DT

Coriolis Mass Flowmeter
ALCM Series

GENERAL

SMC's ALCM-DT Delta Tube Coriolis Mass flowmeter makes use of delta, or triangle shaped measuring tubes in a parallel arrangement. The delta tube geometry provides excellent low-flow performance versus other coriolis tube geometries, making this instrument an ideal choice for applications with smaller line sizes and lower flow rates. The ALCM is offered in line sizes ranging from 1/8" (3mm) to 8" (200mm) and is capable of measuring flow rates from 26 to 2,000,000 lbs per hour at accuracies of up to 0.15% of reading.

The ALCM-DT features an easy-to-read LCD display that can be configured to display either mass or volumetric flow rates in a variety of user-selectable engineering units as well as density, temperature, and totalized flows. This meter offers excellent value by providing a highly accurate, compact instrument that can measure flow, density, and temperature in a single package that has lower cost, lower pressure differential and a more compact design versus competitive coriolis-technology flowmeters. The unique combination of features and benefits offered by the ALCM-DT make it an ideal choice for applications that are found in a variety of industries including Food & Beverage, Petrochem, Oil & Gas, Paint, and Industrial Process Control.

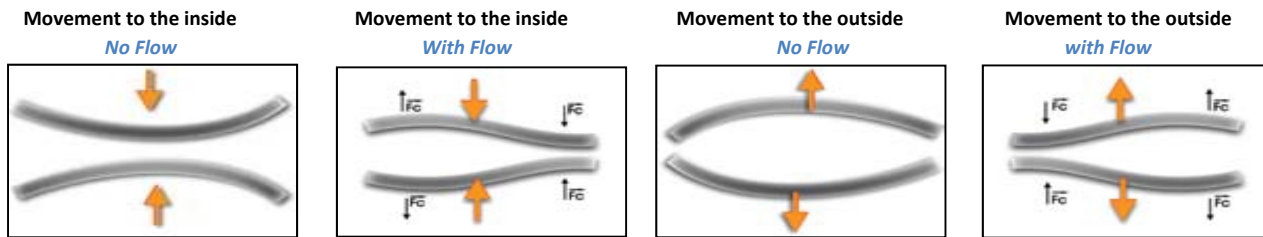

FEATURES

- Suitable for aggressive and contaminated media
- Measurement of mass flow, density, temperature and volume flow with a single instrument
- High rotation frequency and well-balanced measuring tubes
- Excellent accuracy and low-flow performance
- Operation up to + 575°F (300 °C)
- Individual 8-point-calibration including report
- EX protection (optional)

SPECIFICATIONS

- | | | | |
|------------------------|--|--------------------------|---|
| • Flow Range: | 26 ~ 2,000,000Lb/hr. (12~900,000 kg/hr.) | • Zero Drift (%FS / °C): | 0.005 |
| • Line Sizes: | 1/8"~8" (3~200 mm) | • Process Temperature: | -58~392 °F (-50~200 °C) -std |
| • Process Connections: | Threaded (M20*1.5)
Flanged (ANSI, DIN, Tri-Clamp®) | • Ambient Temperature: | -5~312 °F (-20~55 °C) |
| • Tube geometry: | Delta-Tube | • Max Working Pressure: | 360 psig (2.5MPa) std, 930 psig optional |
| • Accuracy: | ±0.5% of reading(std), 0.2% or 0.15% (opt) | • Measuring Tube Mat'l: | SS per DIN1.4571 (AISI 316Ti) standard |
| • Repeatability: | ±0.075% of reading | • Housing Material: | SS #304 |
| • Frequency: | 10-2000 Hz | • Power Supply: | 24 V _{DC} , ± 20%; 86~260V _{AC} , 50~60Hz |
| • Display: | LCD | • Power Consumption: | Less than 6W |
| Eng. Units (mass): | kg, lb., and ton | • Outputs.: | 4-20 mA, 0-10 kHz pulse, RS485 |
| Eng. Units (Temp): | °C, °F | • Density Meas. Range: | 12.5-125lb/ft ³ (0.2~2.0 g/cc) |
| Eng. Units: (Vol.) | m ³ , Liter, US Gallon, Imperial Gallon,
Million Gallon, | • Density Accuracy: | ±0.06 b/ft ³ (0.001 g/cc) |
| • Zero Stability: | 0.1% full-scale | • Temperature Accuracy: | up to ±1°F (°C) |





ALCM-DT

Coriolis Mass Flowmeter
ALCM Series

➤ Flow Ranges

Meter Size (mm)	Weight (kg)	Flow Range Kg/Hr. (Lb./Hr.) (0.2% & 0.5% accuracy)	Stability of Zero Point Kg/Hr. (Lb./Hr.)
DN3	7.0	12~120 (26.5~265)	0.02 (0.044)
DN4	7.0	24~240 (53~530)	0.04 (0.088)
DN6	10.0	80~800 (176~1765)	0.06 (0.132)
DN10	10.0	150~1,500 (330~3,306)	0.11 (0.243)
DN15	12.5	300~3,000 (661~6,614)	0.22 (0.485)
DN20	16.0	700~7,000 (543~15,432)	0.53 (1.169)
DN25	16.5	1,200~12,000 (2,646~26,460)	0.90 (1.984)
DN32	20.6	2,100~21,000 (4,629~46,297)	1.40 (3.087)
DN40	27.0	3,600~36,000 (7,937~79,366)	2.50 (5.512)
DN50	38.0	6,000~60,000 (3,227~132,227)	4.10 (9.039)
DN80	70.0	15,000~150,000 (33,069~330,693)	13.0 (38.66)
DN100	210.0	24,000~240,000 (52,911~529,109)	20.0 (44.09)
DN150	350.0	50,000~500,000 (10,233~1,102,331)	50.0 (110.23)
DN200	500.0	90,000~900,000 (98,416~1,984,160)	100 (220.46)

Accuracy:

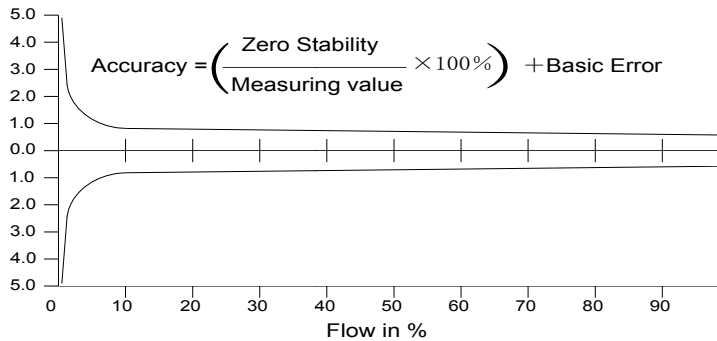

The diagram shows typical values. Individual values may be taken from the calibration records supplied with each meter.

Repeatability:

Accuracy	0.15%	0.20%	0.50%
Repeatability	±0.05%	±0.1%	±0.25%

Density Measuring

Density Range	12.5-125lb/ft ³ (0.2~2.0 g/cc)
Basic Error	±0.06 b/ft ³ (0.001 g/cc) Affected by the transducer
Repeatability	±0.06 b/ft ³ (0.001g/cm ³)





ALCM-DT

Coriolis Mass Flowmeter
ALCM Series

TRANSDUCER

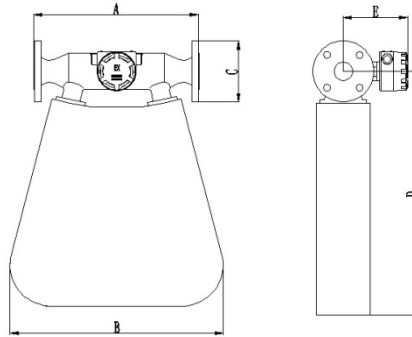

Structure	Quadrilateral					
Pressure rating	PN40	PN64			PN100	
	ANSI150	ANSI300			ANSI600	
Materials	Measurement	316L				
	Shell	304				
	Junction box	Al				
Dimensions (mm)	Size	A	B	C	D	E
	DN3	200	234	Φ90	165	160
	DN4	200	234	Φ90	165	160
	DN6	210	338	Φ90	270	180
	DN10	220	338	Φ90	270	180
	DN15	254	400	Φ95	322	180
	DN20	248	430	Φ105	400	180
	DN25	264	450	Φ115	410	180
	DN32	290	480	Φ140	544	160
	DN40	290	556	Φ150	600	180
	DN50	436	586	Φ165	660	200
	DN80	540	670	Φ200	876	200
	DN100	810	930	Φ235	1082	230
	DN150	1100	1200	Φ300	1500	230
DN200	1300	1200	Φ374	1810	230	

Pressure Loss (Water, 20 °C, 1cst):

Size (mm)	Mass flow (kg/hr)	Pressure drop (bar)	Size (mm)	Measuring (kg/hr)	Pressure drop (bar)	Size (mm)	Mass flow (kg/hr)	Pressure drop (bar)
DN25	1,200	0.07	DN40	3,600	0.011	DN80	15,000	0.01
	4,860	0.10		9,000	0.06		37,500	0.07
	9,320	0.33		18,000	0.24		75,000	0.14
	12,000	0.58		36,000	0.92		150,000	0.52
DN32	2,100	0.02	DN50	6,000	0.01	DN100	24,000	0.04
	5,280	0.09		14,000	0.06		60,000	0.11
	10,500	0.26		28,000	0.22		120,000	0.25
	21,000	0.96		60,000	0.75		240,000	0.49

Density Performance:

Flow Range (kg/m ³)	Intrinsic Error (kg/m ³)
700~1300	±1

Temperature Performance:

Flow Range (°C)	Intrinsic Error (°C)
-60~350	±0.5





ALCM-DT

Coriolis Mass Flowmeter
ALCM Series

Please contact your SmartMeasurement application engineer

You also need to provide the following information:

Type of fluid
Full-scale flow rate
Line Size
Process Pressure & Temperature
Pressure Drop
Type of Electronics
Power Requirements

Please provide the name of your fluid, including operating density and viscosity

Please provide the max and min flow rate, normal flow rate also

Please provide the line size and connection

We will calibrate flow meter as close to your operating conditions as possible

Please indicate the maximum allowable pressure drop

Please specify output and installation type (wall mount, panel mount, etc.)

Please specify AC or DC power supply

➤ Model Selection Guide

ALCM-DT												
Example 1: ALCM-DT-025-F-5-1-N-CBS-NX-DC-NN												
ALCM-DT-	**	**	**	**	**	**	**	**	**	**	**	Description
DN3 (12-120 kg/hr)	003	Nominal Line Size										
DN4 (24-240 kg/hr)	004											
DN6 (80-800 kg/hr)	006											
DN10 (150-1,500 kg/hr)	010											
DN15 (300-3,000 kg/hr)	015											
DN20 (700-7,000 kg/hr)	020											
DN25 (1,200-12,000 kg/hr)	025											
DN32 (2,100-21,000 kg/hr)	032											
DN40 (3,600-36,000 kg/hr)	040											
DN50 (6,000-60,000 kg/hr)	050											
DN80 (15,000-150,000 kg/hr)	080											
DN100 (24,000-240,000 kg/hr)	100											
DN150 (50,000-500,000 kg/hr)	150											
DN200 (90,000-900,000 kg/hr)	200											
ANSI 150 #	F	Process Connections										
ANSI 300# flange	F3											
Other connection	O											
0.15% - For DN6 to DN100	1	Accuracy										
0.2% - For DN6 to DN100	2											
0.5% - standard	5											
1.6 Mpa - standard	1	Working Pressure										
2.5 Mpa	2											
4.0 Mpa	3											
Up to 80 °C - standard	N	Working Temperature										
Up to 150 °C	M											
Up to 250 °C	H											
CB03 Compact Version -local display, 4-20mA, RS485	CBS	Transmitter										
CB03 Compact Version -local display, 4-20mA, RS485 and HART	CBH											
CB03 Remote Version - display, 4-20mA, RS485	RBS											
CB03 Remote Version - display, 4-20mA, RS485 and HART	RBH											
TRO Remote Version - surface touch control, display, 4-20mA, RS485	TRO											
Other transmitter	RE											
Non-Explosion	NX	Approval										
Ex protection EEx d Explosion proof	XD											
24 V _{DC}	DC	Power Supply										
85-260 V _{AC} , 50/60 Hz	AC											
Standard - with 316L measuring tube	NN	Options										
Signal cable for remote type	CABL											
Heat jacket	HJ											

