



ALVAMT

VA METAL TUBE Flowmeter

ALVAMT Series

GENERAL

ALVAMT rugged metal tube variable area meters (rotameters) are ideal for high pressure, high temperature and other demanding flow applications where safety is a concern. Features include: globally-recognized approvals for use in hazardous environments; analog and digital LCD local display options, multiple process connection options; several available materials of construction for metering of aggressive fluids and corrosion resistance; HART enabled 4-20mA output to provide for remote monitoring and control. The ALVAMT's excellent repeatability makes it a good choice for batching applications. For versions without electronic output, no power supply is required. The ALVAMT's low-pressure drop provides additional value by allowing for economical pump selection.

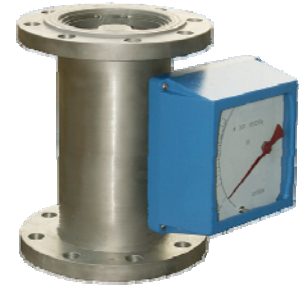

FEATURES

- Excellent low-flow performance
- Versatile design may be used for gas, steam, and liquids
- Low pressure loss for gas and steam applications
- Suitable for high pressure and high temperature applications
- Turn-down ratio of 10:1
- Local indication and intelligent remote LCD display
- Easy-to-read analog pointer style indicator
- Intrinsically safe & explosion proof for hazardous area applications

SPECIFICATION

- Size : 15 ~ 200mm
- Measuring Range Water (20°C) 1.6 ~ 150,000 l/h
Air (20°C, 0.1013MPa) 0.05 ~ 4,000 m³/h
- Temperature Standard (E) -80 ~ +200°C,
PTFE: 0 ~ 85°C
High temperature (H): +200 ~ +300°C
- Pressure Loss 6.5 ~ 15.6 KPa
- Pressure Standard: 1.6MPa (DN65 - DN150)
4.0MPa (DN15 - DN50)
High: 2.5MPa (DN65 - DN150)
6.4MPa (DN15 - DN50)
- Viscosity 15m ~ 20 mm - < 30 CP
25mm ~ 40 mm - < 250 CP
50mm ~ 200mm - < 300 CP
Top enter, Top exit
- Wetted parts SS #304 standard, SS #316 optional
Tantalum (flow tube)
PTEE (flow tube)
PTFE lining
- Flanges ANSI and DIN-type available
- Accuracy ±1.5%(Standard)
±2.5%(PTFE liner)
- Repeatability : ±0.5% of reading



- Signal Output 4-20mA (2-wire)
- Local Display : Mechanical Indicator (standard)
- Digital Display : Rate 0 ~ 50000
Total: 0 ~ 99999999 (with decimal)
- Power Supply : 85-264V_{AC} 50-60 Hz
: 24V_{DC}
3.6V_{DC} @ 5.2 AmpHours Lithium
- Approvals Isolation: Exd II CT5
Intrinsic Safety: Exia II C
- Alarms High / Low limit alarm
maximum 1A @ 24V_{DC}
- Data Storage EEPROM (up to 10 years)
- Flow Orientation Top enter/top exit, Standard
Bottom enter/Top exit
Right enter/Left exit
Left enter/Right exit
- Protection IP 65
- Housing Material : Aluminum
- Cable Connector: M20x1.5 or ½" NPT



Principle

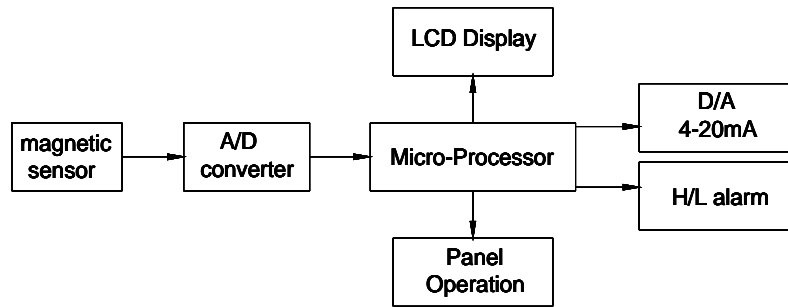
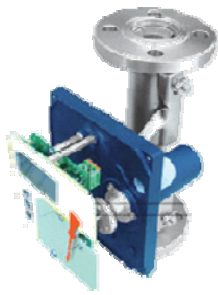

Flow range for various fluids

Meter	Float	Water (LPH)		Air in SCMH
		Material of measuring tube Metal	Material of measuring tube Metal w/ PTFE liner	
DN15	KV15.0	2.5~25		0.07~0.7
	KV15.1	4.0~40	2.5~25	0.11~1.1
	KV15.2	6.0~60	4.0~40	0.18~1.8
	KV15.3	10~100	6.0~60	0.28~2.8
	KV15.4	16~160	10~100	0.4~4.0
	KV15.5	25~250	16~160	0.7~7.0
	KV15.6	40~400	25~250	1.0~10
	KV15.7	60~600	40~400	1.6~16
DN25	KV25.0	100~1,000	60~600	3~30
	KV25.1	160~1,600	100~1,000	4.5~45
	KV25.2	250~2,500	160~1,600	7~70
	KV25.3	400~4,000	250~2,500	11~110
DN50	KV50.0	600~6,000	400~4,000	18~180
	KV50.1	1,000~10,000	600~6,000	25~250
	KV50.2	1,600~16,000	1,000~10,000	40~400
DN80	KV80.0	2,500~25,000	1,600~16,000	75~750
	KV80.1	4,000~40,000	2,500~25,000	100~1,000
DN100	KV100.0	6,000~60,000	4,000~40,000	150~1,500
	KV100.1		6,000~60,000	
DN125	KV125.0	8,000~80,000		
	KV125.1	10,000~100,000		
DN150	KV150.0	15,000~150,000	8,000~80,000	
	KV150.1			
DN200	KV200.0	15,000~150,000		



➤ Bottom enter and top exist (FA type)

● Principle

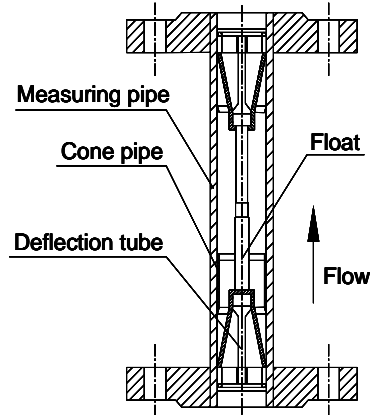

● Dimension

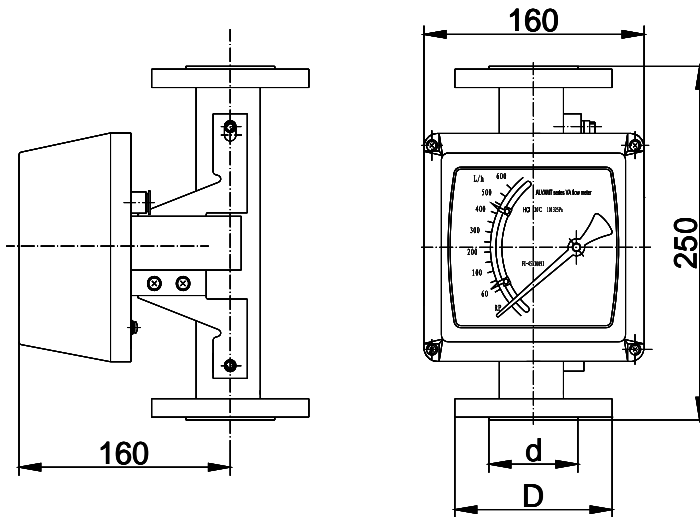

Meter	FA series		
Size	d (mm)	D (mm)	Weight (kg)
DN15	46	95	3.7
DN25	65	115	5.2
DN50	99	165	8.7
DN80	132	200	14.2
DN100	156	220	15.2
DN125	184	250	33.7
DN150	211	285	48.7



**** Please contact your local SMC application engineer**

You also need to provide the following information:

Type of Fluid	Please provide the name of your fluid, including operating density and viscosity
Full Scale Flow	Maximum and minimum flow rates, units must be m ³ /hr, LPM or GPM
Line Size	Please indicate the pipe size as well as connection type (flange, threaded, etc..)
Pressure and Temperature	We will calibrate your flowmeter as close to your operating conditions as possible

➤ Model Selection Guide

ALVAMT Series															
Example: ALVAMT-100-FA-R0-T-KV100.2-N-E-M1-111-S0															
ALVAMT-	**	**	**	**	**	**	**	**	**	**	**	**	**	**	Description
code ** = DN**	**														Size
Bottom entry, top exit	FA														Meter Structure
Bottom entry, top exit horizontal	FB T														
Bottom entry horizontal, top exit horizontal	FC Z														
Right entry, left exit	FDR														
Left entry, right exit	FD														
0Cr ₁₈ Ni ₉ (304)	R0														Material of wetted Tube
SS #316	RL														
PTFE	RP														
Titanium	Ti														
Non	O														Special Type
Jacket	T														
Damping	Z														
Float Number	KV**														Float Number
Standard pressure rating	N														Pressure
High pressure	H														
-80 ~ +150 °C	E														Temperature
-80 ~ +300 °C	H														
Local indicator, square housing	M1														Indicator
Intelligent indicator, square housing	M2														
Intelligent indicator, circular housing (Exid)	M3														
None	0														Signal Output
4-20mA	1														
Without	0														Matching Flange
CS	1														
SS	2														
220V _{AC}	0														Power Supply
24V _{DC}	1														
3.6V Battery	2														
ANSI 150#	S														Flange Standard
ANSI 300#	S3														
PN1.0	1														
None	0														Extra Device
With lining	1														
With PTFE lining	2														

