

# MP500C

Multi-Signal Control Actuators  
for VP220x **SpaceLogic** PIBCV, DN40-100  
(1½" ...4")



## Product Description

MP500C is an linear electro-mechanical actuator for the control of the VP220 **SpaceLogic** PIBCV, DN40-100 (1½" ...4").

MP500C is controlled either by an increase/decrease floating signal or by a range of modulating control signals between the span of 0...10V.

## Features

- Brushless DC motor.
- High resolution control board allows precise fluid control.
- Working range and end point switches calibrate to any stroke and flow setting of the valve.
- A proportional set running time of 15s regardless of valve stroke.
- Multi-signal control for either 3 point increase/decrease signal or various modulating control signals including sequencing.
- The U-Bolt connection allows quick and easy direct mounting onto the **SpaceLogic** PIBCV VP220x valves.
- Stroke Indicators on the yoke provide clear visual indication to the valves opening position.

## Specifications

Supply Voltage	24 Vac +/- 10%, 50...60Hz 24 Vdc +/- 15%
Power consumption	average 15 VA
Transformer sizing	50 VA
Running time	
Modulating	15 s
Increase/decrease	300 s/60 s
Thrust	500N (112 lbf.)
Duty cycle	max. 20%/60 minutes
Analog input (Y-M)	
Voltage Range	0...10 Vdc
Selectable Input signals	2...10 V, 0...5 V, 2...6 V, 5...10 V, 6...10 V
Impedance	minimum 100 k Ohm
Digital input (Y2-Y1)	
Voltage across open input	24 Vac
Current through closed input	5 mA
Pulse time	minimum 20 ms
Output U (Position Feedback Signal)	2...10 V
Load	2 mA

Environmental	
Operation temperature	-10...+50 °C
Storage temperature	-25...+65 °C
Ambient humidity	max. 90% RH non- condensing
Enclosure rating	IP 54 (NEMA 2)
Sound power level	max. 32 dBA

Standards/Directives	
ElectroMagnetic Compatability [EMC]	2014/30/EU
Low voltage directive [LVD]	2014/35/EU
Restriction of Hazardous Substances [RoHS2]	2011/65/EC
Heat	IEC 60068-2-2
Humidity	IEC 60068-2-3
Cold	IEC 60068-2-1
Vibration	IEC 60068-2-6

Material: Housing	Aluminium
Cover	ABS/PC plastic
Color	aluminium/grey
Weight	1.8 kg (3.96 lb.)

## Part Numbers & Accessories

Part No.	Explanation
MP500C	SpaceLogic Multi-signal control actuator
880 0104 000	S2 (Aux Switch)

## Agency Compliance

NA Underwriters Laboratories marked as c.UL.us LISTED under UL873 and CSA C22.2 No.24.

Australia/New Zealand community RCM marked.

## Dimensions (mm)

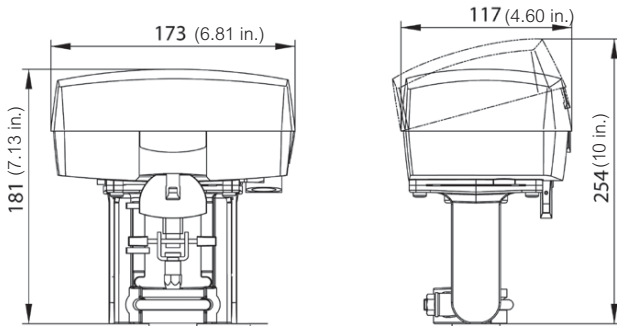

## Function

The actuator utilizes a brushless DC motor to accurately position the main spindle via a gearbox, depending on control signals received from the controller. Upon initial start up the actuator performs a full stroke cycle to learn the valve end stop positions, and calibrates the motor speed and actuator full stroke running time. End switch point adjustment is also calibrated during this process.

## Control Signal

MP500C can either be controlled by an increase/decrease (Floating) digital signal or by a variable direct voltage (Proportional or Modulating). The actuator is very flexible regarding the configuration of signal input and a direct or inverse actuation but normally If an increase/decrease signal is used, the actuator Retracts (moves up) on an increase signal and Extends (moves down) on a decrease signal. See Settings.

## Position Feedback

MP500C actuators are equipped with a 2... 10 Vdc position feedback signal, where 2 V corresponds to the closed position and 10 V to the open position depending on the Dip Switch settings for SW1 and SW7.

## End Point Switch (Accessory Daughter Board)

When fitted, the End point switch (S2 Auxiliary Switch relay) is calibrated during the initial stroke learning procedure. The switch points electronically make at 3% and 97% of the calibrated stroke position. When actuators are controlled in normal or sequence control it is possible to use the end point switches to toggle when the valve is fully open or fully closed.

## Maintenance

The actuator does not require any maintenance.

## Mounting and Installation

The actuator may be mounted horizontally, vertically and in any position in between, but not upside down (Fig. 1).

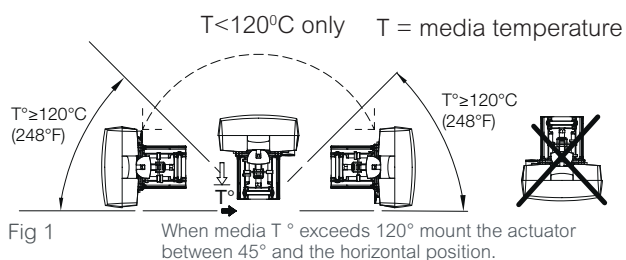

## Manual Operation

MP500C Non-Spring Return actuators have a manual override flip-down or flip-up lever or handle. (Fig. 2). When flipped down, the control signal and power is interrupted to the PCBA. When flipped down, turning the handle raises or lowers the actuator screw jack accordingly. Flipping the lever up again restores the control signal to the board and causes any dipswitch setting changes to be accepted. If any adjustment to the valve flow setting is made, the actuator stroke should be re-calibrated.

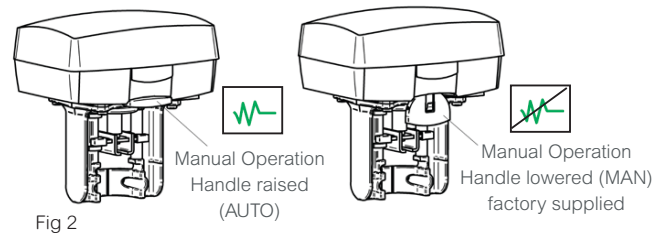

## Wiring and Connections

When installed with 3 conductors, where the control signal reference is connected to  $\downarrow 24$ , the motor current of the actuator will cause varying voltage loss in the cable and thus in the reference level. The MP500C has a highly sensitive control circuitry which can be influenced by interference in the control signal which the actuator can try to follow. This influence may be reduced in simple installations by shortening the cable lengths below 100m and /or increasing the cross sectional area of the cable above 1.5mm<sup>2</sup> (AWG 16) and the cables are spurred to only one actuator.

The DIP switches on the circuit board are set from the factory in OFF position. To make an end position adjustment, move SW9 to the ON (ADJ) position. After an end position adjustment is made MP500C closes the valve fully and when the adjustment is finished the actuator closes the valve again. The electronic circuitry (EEPROM) stores the adjusted stroke and the running time of the valve so they will remain after a loss of power. When the end position adjustment is complete, the actuator starts to control the valve according to the control signal.

Terminal	Function	Description
24~	24 Vac	Supply voltage
$\downarrow 24$	Ground	
Y	Input, proportional	Modulating Control signal
M	Input, neutral, proportional	
Y2	Increase, 3-point	Floating/Digital (Y1, Y2 connected to $\downarrow 24$ )
Y1	Decrease, 3-point	
U	0...100% (2...10 Vdc)	Feedback signal (reference to $\downarrow 24$ )

24~,  $\downarrow 24$ = Max 100 m (328ft.), 1.5 mm<sup>2</sup> (AWG 16)  
Other cables: Max 200 m (656 ft.) 0.5 mm<sup>2</sup> (AWG 20)

## 4-20 mA Control with 500 Ohm Resistor

Controllers requiring 4...20 mA DC current control switch need to have the 500 Ohm resistor (included with the actuator) added to actuator terminals M-Y and SW4 in ON Position.

## Connections/PCB Layout

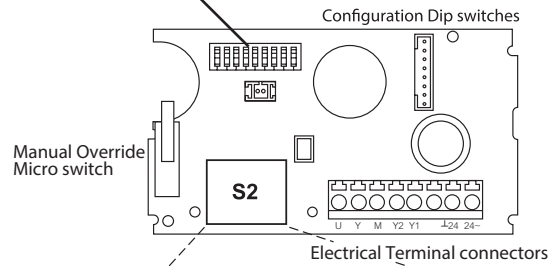
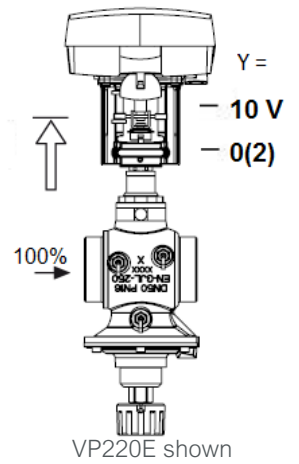
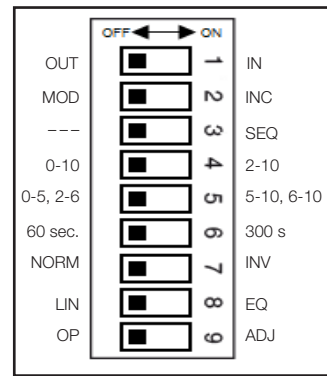
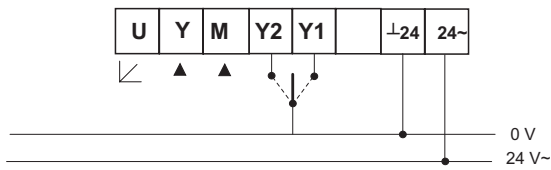
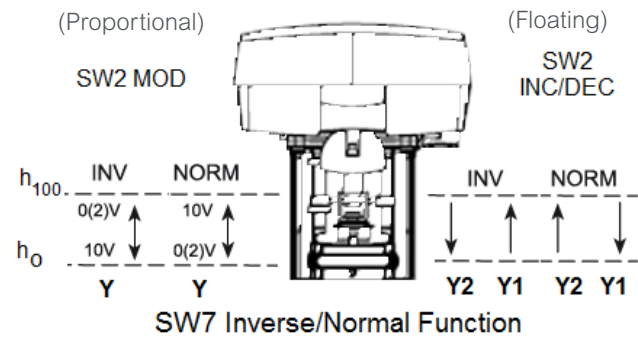

S2 Auxiliary Switch unit, accessory

KC1 to K1 closes upon a fully closed valve.  
 KC2 to K4 opens upon a fully open valve.

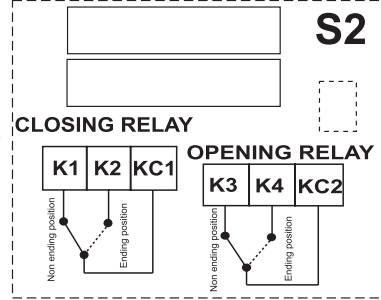

### Increase/Decrease (Floating)

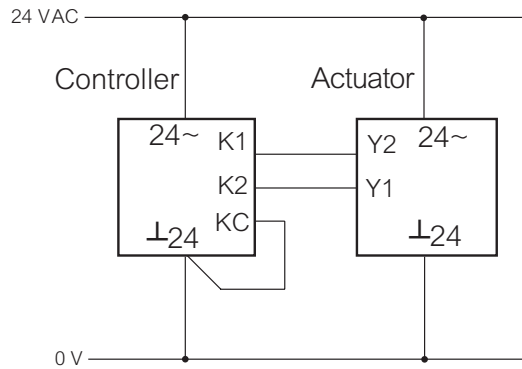

50VA transformer required per actuator.

### Modulating (Proportional)

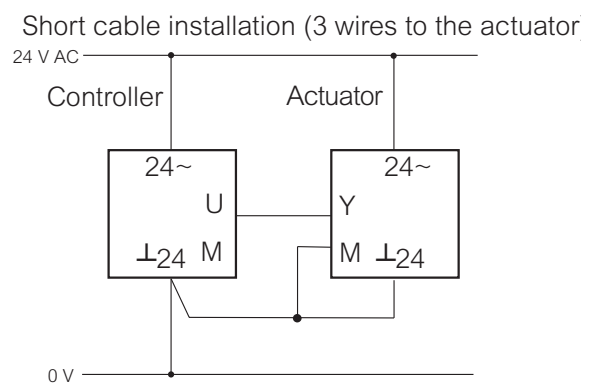
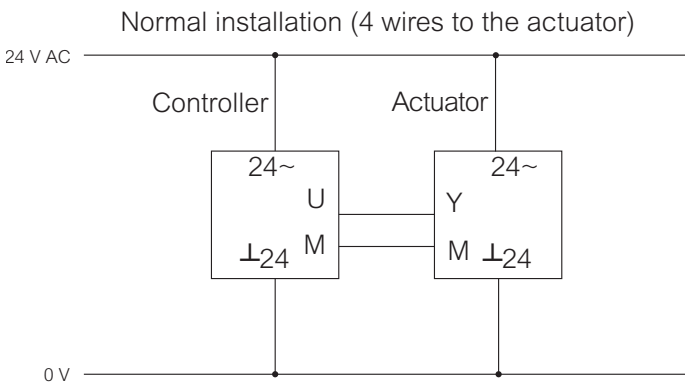

50VA transformer required per actuator.

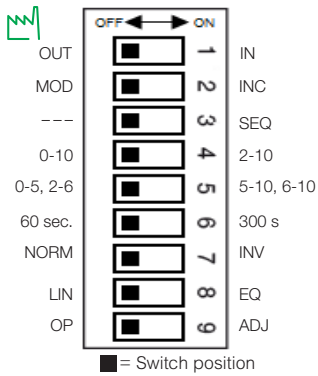

Sw	Description	OFF Position	ON Position
1	Valve closing direction	OUT (extends down to close the valve)	IN (Retracts on a closing signal)
2	Control mode	Modulating	Increase/decrease (floating)
3	Sequence control	-	Sequence
4	Input voltage range	0...10 Vdc	2...10 Vdc
5	Sequential voltage range	0...5 Vdc or 2...6 Vdc	5...10 Vdc or 6...10 Vdc
6	Running time (increase/decrease)	60 s	300 s
7	Normal Direction of movement	Normal	Inverted
8	Flow Characteristic	Linear	EQ
9	Operation/Stroke Calibration	Operation	Stroke Calibration

## Dip Switch Settings

There is a 9 switch configuration block on the circuit board. The factory setting is all switches in the "OFF" position. Adjust these settings prior to engaging power and any subsequent changes to the DIP switches will not be registered until the power is interrupted, or when switch No. 9 is initiated for stroke calibration.

- **SW1 Valve closing direction.**
  - OFF: Actuator fully extends to a closing control signal (normal operation for VP220x **SpaceLogic** PIBCV).
  - ON: Actuator fully retracts on a closing control signal. On power up, the actuator will move to the closed position as set from Switch 1 before becoming under the command of the control signal. The direction of operation from the input control signal and the position feedback signal will also be influenced by switch 7.
- **SW2 Control signal MOD / INC.**
  - MP500C is either controlled by a variable direct voltage, for a modulating signal (MOD), or by a 3-point increase/decrease signal (INC).
- **SW3 Sequence or parallel control - - /SEQ.**
  - With sequence (or parallel) control (SEQ), two actuators/valves can be controlled by only one control signal. See switch 4 and 5 to select the control signal range
  - If sequence or parallel control is not used, the switch - - - / SEQ must be in the OFF position.
- **SW4 Input Voltage range 0...10 / 2...10.**
  - Choose between 0...10 Vdc or 2...10 Vdc control signal range. 0...20mA or 4...20mA is possible with connection of the optional 500 Ohm resistor.
- **SW5 Operational voltage range (0...5, 2...6 / 5...10, 6...10)** When switch 3 (SEQ) is ON choose the operational voltage range.
  - OFF: low: 0...5 V (2...6 V)
  - ON: high: 5...10 V (6...10 V)
 The bracketed control voltage is operational with switch 4 ON.
- **SW6 Running time 60 s / 300 s.**
  - On increase/decrease control, this switch selects the running time between 60 s (Off) or 300 s (On). With modulating control, the running time is always 15 s.
- **SW7 Direction of movement NORM / INV.**
  - OFF (NORM): Normal direction of movement. Actuator retracts to provide an open valve on an open control signal.
  - ON (INV): Inverse direction of movement. Actuator extends to provide a closed valve on an open control signal. This operation is reversed with Sw.1 ON but this may be desired if the power up position according to switch 1 needs to be flipped. Feedback is directly linked to switch 7 and is not influenced by switch 1.
- **SW8 Flow Characteristic LIN/EQ.** The motorized valve characteristics can be modified.
  - The setting EQ will change the VP220x valve from a linear flow characteristic to a modified equal percentage.
- **SW9 Input signal and stroke Calibration OP / ADJ.**
  - This switch is only used to calibrate the stroke end positions.
  - To initiate, momentarily move the switch to the ON position then back to the OFF position. At the end of the adjustment all the other dip switch settings (1 to 8) will be registered again.