

SpaceLogic PIBCV ½"...10"

Pressure Independent Balancing and Control Valve Assemblies



Product Description

The **SpaceLogic** PIBCV range is a comprehensive selection of automatic balancing and control valves that provide flow limitation, with full control authority over hydronic regulation.

Automatic balancing within PIBCV valves provide stable flow regulation regardless of pressure fluctuations in the system and all valves have an adjustable flow limitation set point. The control valve portion of the PIBCV further regulates the water/glycol flow from close-off up to the maximum flow limit setting.

Typical applications are temperature control of chillers, air-handling units, heat exchangers and terminal units such as fan coils, induction units and radiant panels.

Features

- Reduced Energy Consumption
 - Pressure independence ensures no overflow of water/glycol through the valve. Limiting water/glycol flow to the design load of the coil has a significant effect on energy efficiency since systems operate for the majority of the time on a partial load.
 - The overflow of water/glycol causes a degradation in heat transfer at the heat exchanger. Uncontrolled overflow of water/glycol beyond the design flow of the heat exchanger is an extremely wasteful and inefficient use of heat.
- The correct and maximum design flow ensures a high differential in supply and return temperatures to provide high operational efficiency of the chiller or boiler.
- Improved Comfort
 - The **SpaceLogic** PIBCV valves are not affected by other valves in the system that may be opening and closing throughout the day or other piping system disturbances providing more constant, comfortable, room temperatures.
- Reduced Pumping Costs
 - A reduction in overflows through the network reduces pumping costs. A smaller pump head and equipment is required compared to traditional configurations.
- Reduced Installation Costs
 - Only one valve needs to be installed rather than two or three since the **SpaceLogic** PIBCV covers the pressure balancing, flow limitation and control modulation.
- Easy and Quick Commissioning
 - **SpaceLogic** PIBCV setup time is significantly reduced with a simple and accurate flow setting procedure without the need for flow charts, calculations or measuring equipment.
- Improved Reliability
 - Improved mechanical equipment reliability from reduced actuator movements.

Contents

- 2 **SpaceLogic PIBCV Summary**
- 2 Applications
 - 3 Theory
- 3 Control Performance
 - 3 Easy Implementation
- 3 Valve Assembly Part Number System
- 3 Flow Direction
- 4 **SpaceLogic PIBCV Selection Options**
- 4 1. Complete Method: Valve Assembly Selection
- 4 2. Custom Method: Valve Body and Actuator Field Assembly
 - 4 3. Valve Body Only: Automatic Flow Limited Balance Example
- 5 **PIBCV Flow Setting**
- 5 ½...1¼" Size Valves
- 5 PIBCV Flow Setting 5"...10"
- 5 PIBCV Flow Setting 1½"...4"
- 6 **Valve Assembly and Suitable Actuators**
- 6 Table 1. Valve Assemblies ½...1¼" With Female NPT End Connectors, Without PT Ports
- 7 Table 2. Valve Assemblies ½...1¼" With Female NPT End Connectors, With PT Ports
- 7 Table 3. Specification ½...1¼" Valve Body Actuators
- 8 Table 4. Valve Assemblies 1½", 2" With Female NPT End Connectors, With PT Ports
- 8 Table 5. Valve Assemblies 2½"...4" with ANSI Standard B16.1 Flanges, With PT Ports
- 9 Table 6. Specification 1½"...4" Valve Body Actuators
- 9 Table 7. Valve Assemblies 5"...6" With PT Ports with ANSI Standard B16.1 Flanges
- 9 Table 8. Specification 5"...6" Valve Body Actuators
- 10 Table 9. Valve Assembly 8"...10" With PT Ports
- 10 Table 10. Specification 8", 10" Valve Body Actuators
- 10 Table 11. Application: Operation of PIBCV Valve Body Without Actuator
- 11 **Technical Data**
- 11 Table 12. Specification Threaded Version, ½"...2"
- 12 Table 13. Specification Flange Version, 2½"...4"
- 12 Table 14. Specification Flange Version, 5"...10"
- 13 Table 15. Assembly Valve Body Configurations
- 14 Table 16. Selection: Valve Actuator Codes
- 14 Table 17. Selection: ½"...2" Valve Body Tail Pieces
- 15 **Dimensions**
- 15 Threaded Valves 1½"...2" (inches)
- 15 Table 18. Threaded Valves ½ to 1¼" (inches)
- 15 Table 19. Threaded Valves 1½"...2" (inches)
- 16 Flanged Valves 5" and 6"
- 16 Table 20. Flanged Valves 2½"...4" (inches)
- 16 Table 21. Flanged Valves 5" and 6" (inches)
- 17 Flanged Valves 8" and 10"
- 17 Table 22a. Flanged Valves 8" and 10" (inches)
- 17 Table 22b. Valve Flange Adapters 8" and 10"
- 18 Table 23. ½"...2" Valve Flow Ranges (Q_{min} to Q_{nom})
- 19 Table 24. 2½"...10" Flanged Valve Flow Ranges (Q_{min} to Q_{nom})
- 19 Specification Submittal Text

SpaceLogic PIBCV Summary

SpaceLogic PIBCV valves and Actuators can be used with actuators for pressure independent balancing and control applications or without actuators for automatic flow limiting balance applications.

PIBCVs immediately react to all changes in system pressures, providing stable valve control independent from the fluctuating pressures in the piping system. No valve authority, pressure calculations or complicated valve flow setting calculations are required. At partial system load there is no resulting overflow because the valve always limits the flow corresponding to the design flow of the coil.

SpaceLogic PIBCV valves with actuators include an integrated control valve with flow regulation for HVAC applications, plus an automatic flow limiting function for energy efficiency. A full range of Schneider Electric actuators are available for every control application including two position, proportional, floating, spring return open, spring return close, and non-spring return.

Applications

Variable flow systems: A **SpaceLogic** PIBCV with a Schneider Electric actuator is used as a control valve for terminal units, like an AHU (Air Handling Unit), FCU (Fan Coil Unit) or radiation panel, and controls the required flow on every terminal unit maintaining hydronic balance in the system.

Constant flow systems: There are numerous applications in which **SpaceLogic** PIBCV can be used. In a constant flow system with FCUs or in a one pipe heating system, **SpaceLogic** PIBCVs can be installed as an automatic balancing valve in every riser. **SpaceLogic** PIBCVs limit the flow to the set value, thus automatically achieving hydronic balance. Whenever an automatic flow limiter or a control valve is needed, the advantages of cost-saving properties are inherent with **SpaceLogic** PIBCVs. This includes systems with (floor) heating/cooling, concrete core activation or radiation panels.

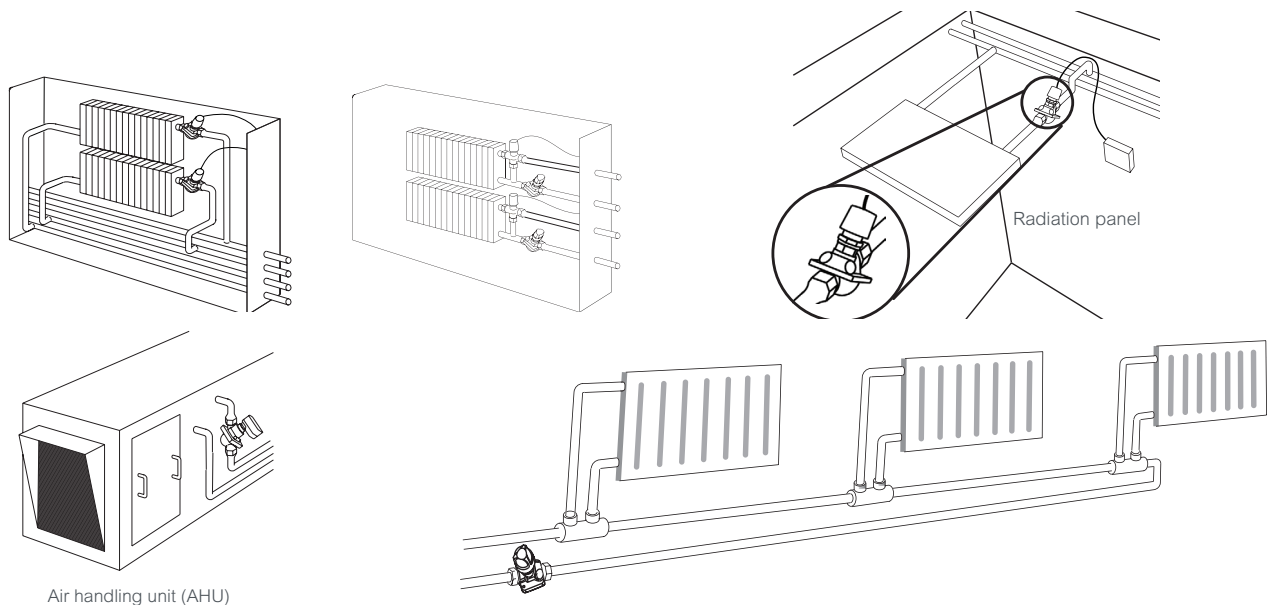

Theory

The **SpaceLogic** PIBCV valve consists of two parts:

1. Differential Pressure Controller
2. Control Valve

1. Differential Pressure Controller (PC)

The differential pressure controller maintains a constant differential pressure across the control valve. The pressure difference is balanced so that when the differential pressure across the control valve changes (due to a change in available pressure, or movement of the control valve) the pressure regulator automatically aligns to a new position. This brings a new equilibrium and therefore keeps the differential pressure at a constant level.

2. Control Valve (CV)

The control valve has a linear characteristic. It features a stroke limitation that allows adjustment of the value. The maximum flow allowed by the control valve can be adjustable to a percentage of the valve's maximum flow rate.

Control Performance

SpaceLogic PIBCV actuators can be used to change the flow response from linear to logarithmic (equal percentage). This makes the **SpaceLogic** PIBCV suitable for all applications, including AHUs, where the equal percentage characteristic is needed to get a stable control loop. The actuators can be switched from linear to equal percentage by changing a dipswitch setting.

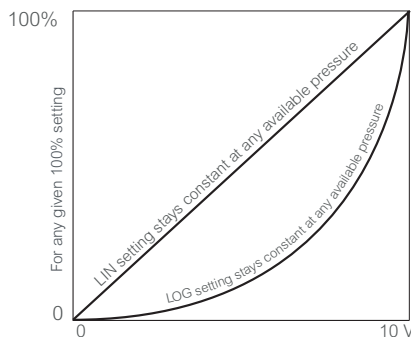

Easy Implementation

- No Cv or authority calculations needed. Flow is the only parameter to be considered when designing.
 - Compact design, essential when only limited space is available such as in fan-coil units.
 - Easy commissioning and troubleshooting. No specialized staff or measuring equipment needed.
 - Trouble-free segmentation of the building project.
- SpaceLogic** PIBCVs will automatically control the flow, even when sections of the installation are unfinished. There is no requirement to re-adjust the **SpaceLogic** PIBCV flow setting after finalization of the building project.

Flow Direction

A **SpaceLogic** PIBCV valve is mono-directional, meaning the valve operates when the arrow on the valve body is aligned with the flow direction. When this rule is ignored, the valve acts as a variable orifice that causes water/glycol hammer at sudden closing when available pressure has increased, or the valve has been set to a lower value.

In the case when a system condition allows backflows, it is strongly recommended to use a backflow preventer in order to avoid possible water/glycol hammer that can damage the valve as well as other elements in the system.

It is recommended to fit a strainer upstream of the valve to increase reliability and to follow water/glycol treatment guidelines as detailed in VDI 2035.

The pipework system should be flushed prior to the operation.

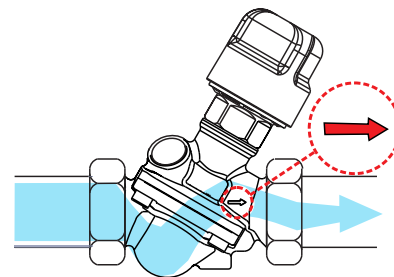

Valve Assembly Part Number System

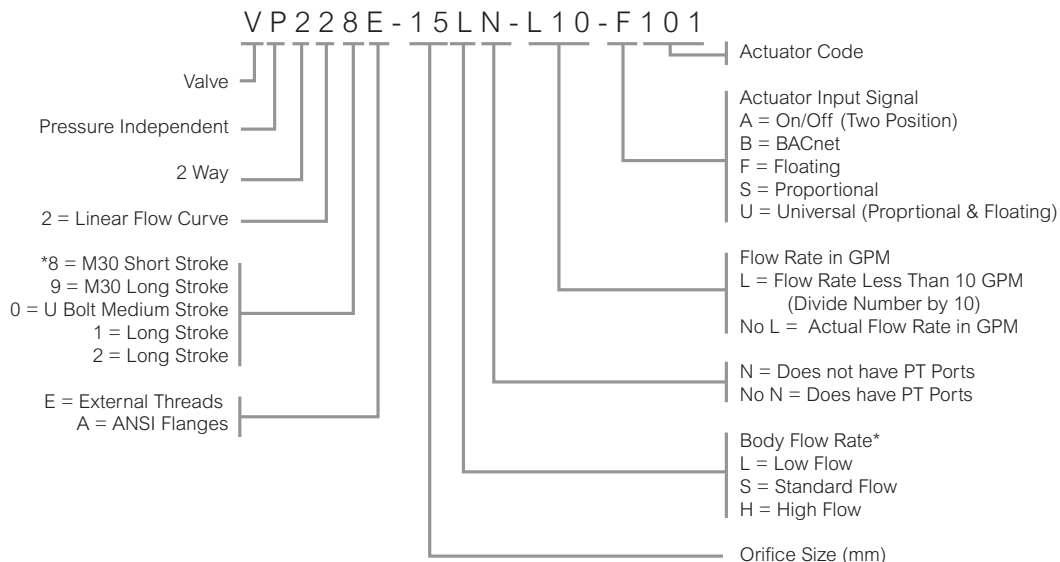

* Determined by valve size and flow; see tables 23 & 24

SpaceLogic PIBCV Selection Options

There are three methods for selecting **SpaceLogic** PIBCV valves and Actuators:

1. **Complete Method: Valve Assembly Selection**
2. **Custom Method: Valve Body and Actuator Field Assembly**
3. **Valve Only Method: Automatic Flow Limited Balance**

1: Complete Method: Valve Assembly Selection

To select a PIBCV valve assembly select the required flow rate and actuator type. For example, to select a PIBCV valve assembly with a flow rate of 1.5 GPM and a non-spring return proportional actuator refer to Table 1. Valve Assemblies ½...1¼" With Female NPT End Connectors, Without PT Ports on page 6.

Select the 1.5 GPM flow rate with the left column of the table.

Select the actuator from the top row of the table.

The intersecting valve assembly part number from the left column and top row selections shows VP228E-15SN-L15-S101 which includes the set 1.5 GPM flow rate, installed actuator, female NPT end connectors, and metal tag with flow rate.

Specifications for the selected valve body actuators are in Table 3. Specification ½...1¼" Valve Body Actuators on page 7 and for the valve body in Table 12. Specification Threaded Version, ½...2" on page 11.

2. Custom Method: Valve Body and Actuator Field Assembly

Select the individual parts then set the flow rate and field assemble a valve assembly.

Table 12. Specification Threaded Version, ½...2" on page 11 shows the valve body specifications and Table 23. ½...2" Valve Flow Ranges (Q_{min} to Q_{nom}) on page 18, and Table 24. 2½"...10" Flanged Valve Flow Ranges (Q_{min} to Q_{nom}) on page 19, show the valve body flow rate ranges.

For example, to select a valve body that can be used in the flow rate range of 1 to 2 GPM, from Table 23. ½...2" Valve Flow Ranges (Q_{min} to Q_{nom}) on page 18, select the VP-228E-15BQSNT valve body that does not include PT ports, or select the VP-228E-15BSQ valve body if PT Ports are required.

Other larger valves could also provide the 1 to 2 GPM flow rates, but the VP-228E-15BQSNT was selected because it will be using a higher percentage of its flow range (in general, best accuracy is achieved when a higher percentage of flow rate is used).

The ½" to 2" PIBCV valves use convenient valve body tail pieces for connection to the piping system.

From Table 17. Selection: ½"...2" Valve Body Tail Pieces on page 14, select the desired ½" tail piece – part number 9112108015 for Female NPT, 9112110015 for Male NPT, or 9112109015 for Sweat. Each tail piece part number includes two tail pieces.

Table 3. Specification ½...1¼" Valve Body Actuators on page 7 shows the compatible actuators.

Select the MP131-24T for two position control, the MP131-24F for floating control, the MP-131-24MP for proportional control, the MP300-SRU for spring return open universal control, or the MP300-SRD for spring return close universal control. Universal control actuators provide both proportional and floating input functionality. The valve body flow can easily be set before the actuator is installed as shown in the PIBCV Flow Setting on page 5.

3. Valve Body Only: Automatic Flow Limited Balance Example

PIBCV valves can be used without actuators to limit the circuit flow to an adjustable flow rate.

Table 12. Specification Threaded Version, ½...2" on page 11 shows the valve body specifications and Table 23. ½...2" Valve Flow Ranges (Q_{min} to Q_{nom}) on page 18 and Table 24. 2½"...10" Flanged Valve Flow Ranges (Q_{min} to Q_{nom}) on page 19 show the valve body flow rate ranges.

For example, to select a valve body that can be used in the flow rate range of 2 to 5 GPM from Table 23 select the VP229E-15BQHNT valve body part number. The ½" to 2" PIBCV valves use convenient valve body tail pieces for connection to the piping system.

From Table 17. Selection: ½"...2" Valve Body Tail Pieces on page 14, select the desired ½" tail piece: part number 9112108015 for Female NPT, 9112110015 for Male NPT, or 9112109015 for Sweat. Each tail piece part number includes two tail pieces.

The 1½" and larger sized valves require a stem lock when used without an actuator as shown in Table 11. Application: Operation of PIBCV Valve Body Without Actuator on page 10 (which also shows application information for the valve bodies without actuators). The valve body flow can easily be set as shown in the PIBCV Flow Setting Section.

PIBCV Flow Setting

1/2...1 1/4" Size Valves

The calculated flow can be adjusted easily without using special tools. To change the presetting (factory setting is 100% for separately purchased PIBCV valve bodies) follow the four steps below:

- 1 Remove the black protective cover or the mounted actuator.
- 2 Raise the green pointer.
- 3 Turn (clock wise to decrease) to the new presetting.
- 4 Press the pointer back into the lock position. After the pointer is clicked back into place the presetting is locked.

The presetting scale indicates values from 100% flow to 20%. Clock wise turning would decrease the flow value while counter clock wise would increase it.

Example: VP229E-15HN

With this 1/2" valve the nom flow = 5 gal/min = 100% presetting.

To set a flow of 4 gal/min you have to set: $4/5 = 80\%$.

Schneider Electric recommends a presetting/flow from 20% to 100%.

To set a PIBCV valve to a Q_{high} setting above 100%, turn the green pointer counter clock wise from 100%. The Q_{high} setting is the scale setting plus 90%. For example, to set the VP229E-15HN to a flow rate of 5.5 gal/min, set $5.5/5.0 = 110\%$ setting. Obtain the 110% setting by turning the green pointer counter clock wise from 100% to 20% (20% and 90% = 110%). As shown on page 11, Q_{high} settings above 100% slightly increase the valve's required minimum differential pressure.

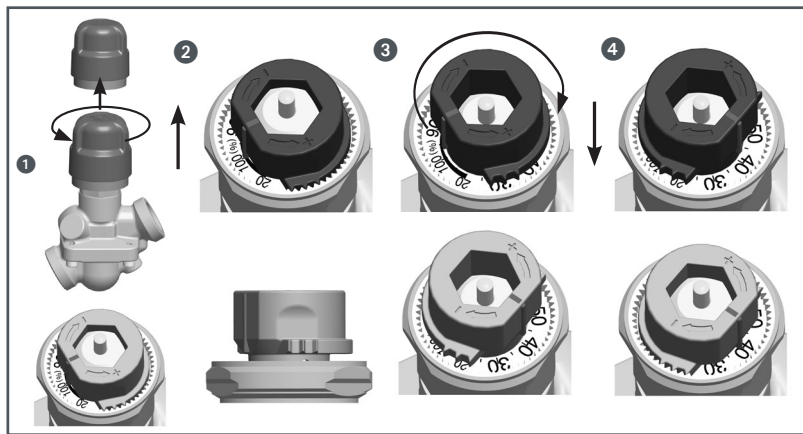

PIBCV Flow Setting 5"...10"

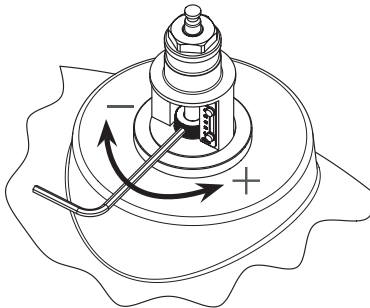

Note:
1 turn = 5%

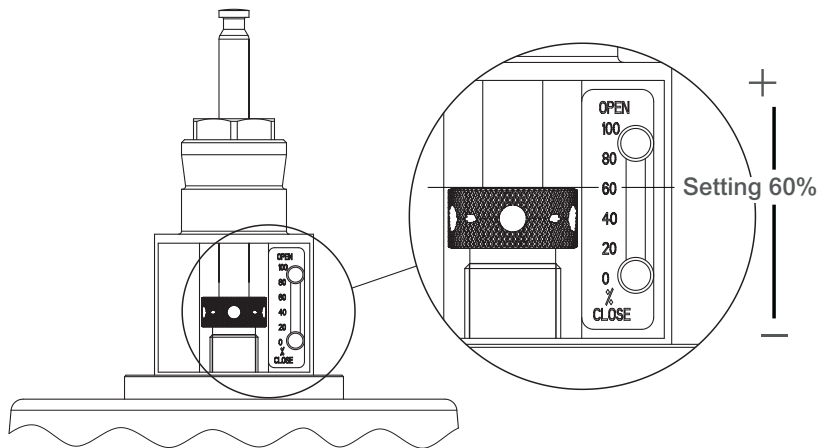

PIBCV Flow Setting 1 1/2"...4"

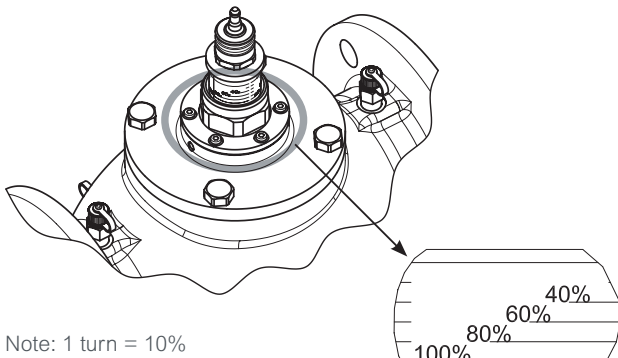

Note: 1 turn = 10%

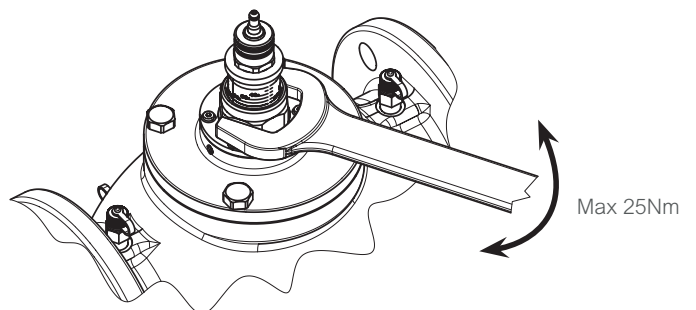

Max 25Nm

Valve Assembly and Suitable Actuators

Table 1. Valve Assemblies ½...1¼" With Female NPT End Connectors, Without PT Ports

Flow Rate (GPM) ^a	Valve Size (inch)	24 Vac Two Position with Auxiliary Switch (MP131-24T)	24 Vac Three Wire Floating with Auxiliary Switch (MP131-24F)	24 Vac Proportional with Position Output Signal (MP131-24MP)	24 Vac Proportional/Floating with Position Output Signal Spring Return Open (MP300-SRU)	24 Vac Proportional/Floating with Position Output Spring Return Closed (MP300-SRD)
						
0.5	1/2	VP228E-10LN-L05-A101	VP228E-10LN-L05-F101	VP228E-10LN-L05-S101	VP228E-10LN-L05-U201	VP228E-10LN-L05-U301
1.0	1/2	VP228E-15LN-L10-A101	VP228E-15LN-L10-F101	VP228E-15LN-L10-S101	VP228E-15LN-L10-U201	VP228E-15LN-L10-U301
1.5	1/2	VP228E-15SN-L15-A101	VP228E-15SN-L15-F101	VP228E-15SN-L15-S101	VP228E-15SN-L15-U201	VP228E-15SN-L15-U301
2.0	1/2	VP228E-15SN-L20-A101	VP228E-15SN-L20-F101	VP228E-15SN-L20-S101	VP228E-15SN-L20-U201	VP228E-15SN-L20-U301
2.5	1/2	VP229E-15HN-L25-A101	VP229E-15HN-L25-F101	VP229E-15HN-L25-S101	VP229E-15HN-L25-U201	VP229E-15HN-L25-U301
3.0	1/2	VP229E-15HN-L30-A101	VP229E-15HN-L30-F101	VP229E-15HN-L30-S101	VP229E-15HN-L30-U201	VP229E-15HN-L30-U301
3.5	1/2	VP229E-15HN-L35-A101	VP229E-15HN-L35-F101	VP229E-15HN-L35-S101	VP229E-15HN-L35-U201	VP229E-15HN-L35-U301
4.0	1/2	VP229E-15HN-L40-A101	VP229E-15HN-L40-F101	VP229E-15HN-L40-S101	VP229E-15HN-L40-U201	VP229E-15HN-L40-U301
4.0	3/4	VP228E-20SN-L40-A101	VP228E-20SN-L40-F101	VP228E-20SN-L40-S101	VP228E-20SN-L40-U201	VP228E-20SN-L40-U301
4.5	1/2	VP229E-15HN-L45-A101	VP229E-15HN-L45-F101	VP229E-15HN-L45-S101	VP229E-15HN-L45-U201	VP229E-15HN-L45-U301
5.0	1/2	VP229E-15HN-L50-A101	VP229E-15HN-L50-F101	VP229E-15HN-L50-S101	VP229E-15HN-L50-U201	VP229E-15HN-L50-U301
5.5	3/4	VP229E-20HN-L55-A101	VP229E-20HN-L55-F101	VP229E-20HN-L55-S101	VP229E-20HN-L55-U201	VP229E-20HN-L55-U301
6.0	3/4	VP229E-20HN-L60-A101	VP229E-20HN-L60-F101	VP229E-20HN-L60-S101	VP229E-20HN-L60-U201	VP229E-20HN-L60-U301
6.5	3/4	VP229E-20HN-L65-A101	VP229E-20HN-L65-F101	VP229E-20HN-L65-S101	VP229E-20HN-L65-U201	VP229E-20HN-L65-U301
7.0	3/4	VP229E-20HN-L70-A101	VP229E-20HN-L70-F101	VP229E-20HN-L70-S101	VP229E-20HN-L70-U201	VP229E-20HN-L70-U301
7.5	3/4	VP229E-20HN-L75-A101	VP229E-20HN-L75-F101	VP229E-20HN-L75-S101	VP229E-20HN-L75-U201	VP229E-20HN-L75-U301
7.5	1	VP229E-25SN-L75-A101	VP229E-25SN-L75-F101	VP229E-25SN-L75-S101	VP229E-25SN-L75-U201	VP229E-25SN-L75-U301
8	1	VP229E-25HN-L80-A101	VP229E-25HN-L80-F101	VP229E-25HN-L80-S101	VP229E-25HN-L80-U201	VP229E-25HN-L80-U301
8.5	1	VP229E-25HN-L85-A101	VP229E-25HN-L85-F101	VP229E-25HN-L85-S101	VP229E-25HN-L85-U201	VP229E-25HN-L85-U301
9.0	1	VP229E-25HN-L90-A101	VP229E-25HN-L90-F101	VP229E-25HN-L90-S101	VP229E-25HN-L90-U201	VP229E-25HN-L90-U301
9.5	1	VP229E-25HN-L95-A101	VP229E-25HN-L95-F101	VP229E-25HN-L95-S101	VP229E-25HN-L95-U201	VP229E-25HN-L95-U301
10	1	VP229E-25HN-010-A101	VP229E-25HN-010-F101	VP229E-25HN-010-S101	VP229E-25HN-010-U201	VP229E-25HN-010-U301
11	1	VP229E-25HN-011-A101	VP229E-25HN-011-F101	VP229E-25HN-011-S101	VP229E-25HN-011-U201	VP229E-25HN-011-U301
12	1	VP229E-25HN-012-A101	VP229E-25HN-012-F101	VP229E-25HN-012-S101	VP229E-25HN-012-U201	VP229E-25HN-012-U301
13	1¼	VP229E-32SN-013-A101	VP229E-32SN-013-F101	VP229E-32SN-013-S101	VP229E-32SN-013-U201	VP229E-32SN-013-U301
14	1¼	VP229E-32SN-014-A101	VP229E-32SN-014-F101	VP229E-32SN-014-S101	VP229E-32SN-014-U201	VP229E-32SN-014-U301
15	1¼	VP229E-32HN-015-A101	VP229E-32HN-015-F101	VP229E-32HN-015-S101	VP229E-32HN-015-U201	VP229E-32HN-015-U301
16	1¼	VP229E-32HN-016-A101	VP229E-32HN-016-F101	VP229E-32HN-016-S101	VP229E-32HN-016-U201	VP229E-32HN-016-U301
17	1¼	VP229E-32HN-017-A101	VP229E-32HN-017-F101	VP229E-32HN-017-S101	VP229E-32HN-017-U201	VP229E-32HN-017-U301

a. Factory set. Complete flow ranges shown in tables for 1/2...2" on page 11 and page 18.

Table 2. Valve Assemblies 1/2...1 1/4" With Female NPT End Connectors, With PT Ports

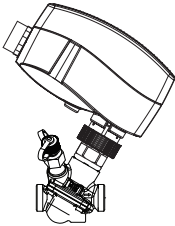
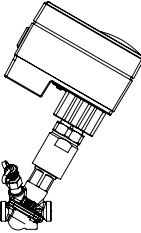
Flow Rate (GPM) ^a	Valve Size (inch)	24 Vac Two Position with Auxiliary Switch (MP131-24T)	24 Vac Three Wire Floating with Auxiliary Switch (MP131-24F)	24 Vac Proportional with Position Output Signal (MP131-24MP)	24 Vac Proportional/Floating Spring Return Open (MP300-SRU)	24 Vac Proportional/Floating Spring Return Closed (MP300-SRD)
						
0.5	1/2	VP228E-10L-L05-A101	VP228E-10L-L05-F101	VP228E-10L-L05-S101	VP228E-10L-L05-U201	VP228E-10L-L05-U301
1.0	1/2	VP228E-15L-L10-A101	VP228E-15L-L10-F101	VP228E-15L-L10-S101	VP228E-15L-L10-U201	VP228E-15L-L10-U301
1.5	1/2	VP228E-15S-L15-A101	VP228E-15S-L15-F101	VP228E-15S-L15-S101	VP228E-15S-L15-U201	VP228E-15S-L15-U301
2.0	1/2	VP228E-15S-L20-A101	VP228E-15S-L20-F101	VP228E-15S-L20-S101	VP228E-15S-L20-U201	VP228E-15S-L20-U301
4.0	3/4	VP228E-20S-L40-A101	VP228E-20S-L40-F101	VP228E-20S-L40-S101	VP228E-20S-L40-U201	VP228E-20S-L40-U301
7.5	1	VP229E-25S-L75-A101	VP229E-25S-L75-F101	VP229E-25S-L75-S101	VP229E-25S-L75-U201	VP229E-25S-L75-U301
14	1 1/4	VP229E-32S-014-A101	VP229E-32S-014-F101	VP229E-32S-014-S101	VP229E-32S-014-U201	VP229E-32S-014-U301



a. Factory set. Complete flow ranges shown in tables for 1/2...2" on page 11 and page 18.

Table 3. Specification 1/2...1 1/4" Valve Body Actuators

1/2" to 1 1/4" Valve Body Actuator Part Number (actuator code)	MP131-24T (A101)	MP131-24F (F101)	MP131-24MP (S101)	MP300-SRU (U201)	MP300-SRD (U301)
Input Signal	Two Position, 3 Wire with selectable input jumper signal action selection		Three Wire Floating	Proportional, 0...10 Vdc, 2...10 Vdc, 4...20 mA, sequencing with selectable input signal action, DIP switch selectable	
Electrical Connection	Screw terminal with conduit connector				
Position Feedback Output Signal	-	-	0...10 Vdc	0...10 Vdc, 2...10 Vdc	
Spring Return	-	-	-	Open Valve	Close Valve
Auxiliary Switch	Yes	Yes	-	-	-
Other Features	-	-	Weekly anti blocking selection, auto calibration, LED indication	Valve stroke length selection, LED indication	
Linear/Equal% Valve Flow Curve Selection	-	-	Yes	Yes	
Actuator Speed s/mm 60 Hz (50 Hz)	20 (24)			11.7 (14)	
Power Consumption	1 VA		1.5 VA	9 VA	
Actuator Weight (lb.)	.9			2.0	1.3
Operating Temperature Limits °F (°C)	32...131 (0...55)				
Regulatory Compliance	cULus according to UL 60730-1A/-2-14 and CAN/CSA E60730-1/-2-14 and CE according to EN 60730-1/-2-14 per EMC [2014/30/EU] and LVD [2014/35/EU]				
Specification Data Sheet	F-27961			F-27962	
Installation Data sheet	F-27938	F-27949	F-27948	F-27954	

All actuators are 24 Vac. 50/60 HZ with removable conduit connector plate and wiring terminal block, manual override

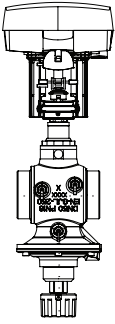
Table 4. Valve Assemblies 1½", 2" With Female NPT End Connectors, With PT Ports

Flow Rate (GPM) ^a	Valve Size (inch)	24 Vac Proportional with Position Output Signal (MP500C)	24 Vac Proportional/Floating with Position Output Signal Spring Return Open (MP500C-SRU or MP500C-SRU-W)	24 Vac Proportional/Floating with Position Output Signal Spring Return Closed (MP500C-SRD or MP500C-SRD-W)
			Use actuator code U234 for IP65 (NEMA 4) SRU	 Use actuator code U334 for IP65 (NEMA 4) SRD
18	1½	VP220E-40S-018-U131	VP220E-40S-018-U231	VP220E-40S-018-U331
19	1½	VP220E-40S-019-U131	VP220E-40S-019-U231	VP220E-40S-019-U331
20	1½	VP220E-40S-020-U131	VP220E-40S-020-U231	VP220E-40S-020-U331
22	1½	VP220E-40S-022-U131	VP220E-40S-022-U231	VP220E-40S-022-U331
24	1½	VP220E-40S-024-U131	VP220E-40S-024-U231	VP220E-40S-024-U331
26	1½	VP220E-40S-026-U131	VP220E-40S-026-U231	VP220E-40S-026-U331
28	1½	VP220E-40S-028-U131	VP220E-40S-028-U231	VP220E-40S-028-U331
30	1½	VP220E-40S-030-U131	VP220E-40S-030-U231	VP220E-40S-030-U331
32	1½	VP220E-40S-032-U131	VP220E-40S-032-U231	VP220E-40S-032-U331
34	2	VP220E-50S-034-U131	VP220E-50S-034-U231	VP220E-50S-034-U331
36	2	VP220E-50S-036-U131	VP220E-50S-036-U231	VP220E-50S-036-U331
38	2	VP220E-50S-038-U131	VP220E-50S-038-U231	VP220E-50S-038-U331
40	2	VP220E-50S-040-U131	VP220E-50S-040-U231	VP220E-50S-040-U331
44	2	VP220E-50S-044-U131	VP220E-50S-044-U231	VP220E-50S-044-U331
48	2	VP220E-50S-048-U131	VP220E-50S-048-U231	VP220E-50S-048-U331
52	2	VP220E-50S-052-U131	VP220E-50S-052-U231	VP220E-50S-052-U331

a. Factory set. Complete flow ranges shown in tables for 1/2"...2" on page 11 and page 18.

Table 5. Valve Assemblies 2½"...4" with ANSI Standard B16.1 Flanges, With PT Ports

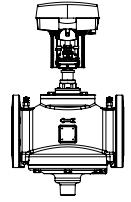
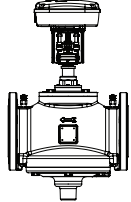
Flow Rate (GPM) ^a	Valve Size (inch)	24 Vac Proportional with Position Output Signal (MP500C)	24 Vac Proportional/Floating with Position Output Signal Spring Return Open (MP500C-SRU or MP500C-SRU-W)	24 Vac Proportional/Floating with Position Output Signal Spring Return Closed (MP500C-SRD or MP500C-SRD-W)
			Use actuator code U234 for IP65 (NEMA 4) SRU	 Use actuator code U334 for IP65 (NEMA 4) SRD
56	2½	VP220A-65S-056-U131	VP220A-65S-056-U231	VP220A-65S-056-U331
60	2½	VP220A-65S-060-U131	VP220A-65S-060-U231	VP220A-65S-060-U331
65	2½	VP220A-65S-065-U131	VP220A-65S-065-U231	VP220A-65S-065-U331
70	2½	VP220A-65S-070-U131	VP220A-65S-070-U231	VP220A-65S-070-U331
75	2½	VP220A-65S-075-U131	VP220A-65S-075-U231	VP220A-65S-075-U331
80	2½	VP220A-65S-080-U131	VP220A-65S-080-U231	VP220A-65S-080-U331
90	3	VP220A-80S-090-U131	VP220A-80S-090-U231	VP220A-80S-090-U331
100	3	VP220A-80S-100-U131	VP220A-80S-100-U231	VP220A-80S-100-U331
110 (min. 44)	2½	VP220A-65H-110-U131	VP220A-65H-110-U231	VP220A-65H-110-U331
165 (min. 66)	4	VP220A-100S-165-U131	VP220A-100S-165-U231	VP220A-100S-165-U331
176 (min. 70)	3	VP220A-80H-176-U131	VP220A-80H-176-U231	VP220A-80H-176-U331
260 (min. 104)	4	VP220A-100H-260-U131	VP220A-100H-260-U231	VP220A-100H-260-U331

a. Factory set. Complete flow ranges shown in tables for 2½"...4" on page 12 and page 19.

Table 6. Specification 1½”...4” Valve Body Actuators

1½”...4” Valve Body Actuator Part Number (actuator code)	MP500C (U131)	MP500C-SRU (U231)	MP500C-SRD (U331)	MP500C-SRU-W (U234)	MP500C-SRD-W (U334)
Input Signal	Proportional, 0...10 Vdc, 2...10 Vdc, 4...20 mA, sequencing with selectable input signal action and Floating, DIP switch selectable				
Electrical Connection	Screw terminal with conduit connector				
Position Feedback Output Signal	2...10 Vdc	2...10 Vdc, 0...5 Vdc		2...10 Vdc, 0...5 Vdc	
Spring Return	–	Open Valve	Close Valve	Open Valve	Close Valve
Auxiliary Switch	Optional Module (8800104000 Dual Form C End Switches)				
Other Features	Auto calibration, field selectable floating input signal travel time, powered manual override		Auto calibration, field selectable floating input signal travel time		
Linear/Equal% Valve Flow Curve Selection	Yes				
Actuator Speed Full Stroke 60 Hz (50 Hz)	Proportional 15 (15) Floating 60 or 300 (60 or 300)		Proportional 15 (15) Floating 60 or 300 (60 or 300) Spring Return 13 (13)		
Power Consumption	Running 15 VA, Transformer Sizing 50 VA		Running 30 VA, Transformer Sizing 50 VA		
Operating Temperature Limits °F (°C)	14...122 (-10...50)				
Enclosure Rating	IP54 (NEMA 2)	IP54 (NEMA 2)	IP54 (NEMA 2)	IP65 (NEMA 4)	IP65 (NEMA 4)
Actuator Weight (lb.)	4.0		6.0		
Regulatory Compliance	Underwriters Laboratory (E9429) compliance as Temperature Indicating & Regulatory Equipment cULus LISTED per UL873 and Canadian Standard C22.2 No. 24. European Community compliance per EMC directive (2014/30/EU) and LVD directive (2014/35/EU). Australian/New Zealand community RCM mark.				
Specification Data Sheet	F-27944		F-27945		F-27945
Installation Data sheet	F-27942		F-27943		F-27943

All actuators are 24 Vac. 50/60 HZ with conduit connector holes and wiring terminal block, manual override

Table 7. Valve Assemblies 5” and 6” With PT Ports with ANSI Standard B16.1 Flanges

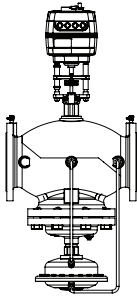
Flow Rate (GPM) ^a	Valve Size (inch)	24 Vac Proportional with Position Output Signal (MP2000-NSR)	24 Vac Proportional/Floating with Position Output Signal Spring Return Open (MP2000-SRU)	24 Vac Proportional/Floating with Position Output Signal Spring Return Closed (MP2000-SRD)
				
395 (min. 158)	5	VP220A-125S-395-U161	VP220A-125S-395-U261	VP220A-125S-395-U361
485 (min. 194)	5	VP220A-125H-485-U161	VP220A-125H-485-U261	VP220A-125H-485-U361
640 (min. 256)	6	VP220A-150S-640-U161	VP220A-150S-640-U261	VP220A-150S-640-U361
830 (min. 332)	6	VP220A-150H-830-U161	VP220A-150H-830-U261	VP220A-150H-830-U361

a. Factory set. Complete flow ranges shown in tables for 5”...6” on page 12 and page 19.

Table 8. Specification 5”and 6” Valve Body Actuators

5” and 6” Valve Body Actuator Part Number (actuator code)	MP2000-NSR (U161)	MP2000-SRU (U261)	MP2000-SRD (U361)
Input Signal	Proportional, 0...10 Vdc, 2...10 Vdc, 0...20 mA, 4...20 mA, with selectable input signal action and Floating, DIP switch selectable		
Electrical Connection	Screw terminal with conduit connector		
Position Feedback Output Signal	0...10 Vdc, 2...10 Vdc, 0...20 mA, 4...20 mA ^a		
Spring Return	–	Open Valve	Close Valve
Auxiliary Switch	Yes		
Other Features	Auto calibration, 3-color LED indication, powered manual override, configurable position output signals, selectable speed, adjustable equal percentage flow curve		
Linear/Equal% Valve Flow Curve Selection	Yes		
Actuator Speed s/mm 60 Hz (50 Hz)	3 or 6 (3 or 6)		4 or 6 (4 or 6)
Power Consumption	15.0 VA		
Operating Temperature Limits °F (°C)	32...131 (0...55)		
Actuator Weight (lb.)	13.8		18.96
Regulatory Compliance	cULus according to UL 60730-1A/-2-14 and CAN/CSA E60730-1/-2-14 and CE according to EN 60730-1/-2-14 per EMC [2014/30/EU] and LVD [2014/35/EU]		
Specification Data Sheet	F-27976		F-27969
Installation Data sheet	F-27956		

a. When used with a proportional input signal. All actuators are 24 Vac. 50/60 HZ with conduit connector holes and wiring terminal block, manual override

Table 9. Valve Assembly 8” and 10” With PT Ports

Flow Rate (GPM)	* Valve Size (inch)	24 Vac Proportional with Position Output Signal (MP4000)
880 (min. 352)	8	VP222A-200S-880-U181
1188 (min. 475)	8	VP222A-200H-1188-U181
1320 (min. 528)	10	VP222A-250S-1320-U181
1630 (min. 652)	10	VP222A-250H-1630-U181

* Factory set. Complete flow ranges are shown in tables for 8” and 10” on page 12 and page 19.

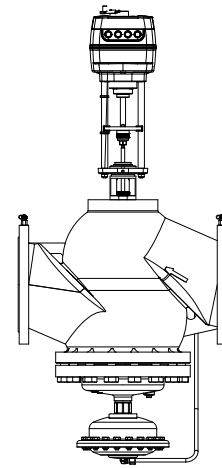

Table 10. Specification 8” and 10” Valve Body Actuators

8” and 10” Valve Body Actuator Part Number (actuator code)	MP4000 (U181)
Input Signal	Proportional, 0...10 Vdc, 2...10 Vdc, 0...20 mA, 4...20 mA, with selectable input signal action and Floating, DIP switch selectable
Electrical Connection	Screw terminal with conduit connector
Position Feedback Output Signal	0...10 Vdc, 2...10 Vdc, 0...20 mA, 4...20 mA ^a
Spring Return	–
Auxiliary Switch	Yes
Other Features	Auto calibration, LED indication, powered manual override, adjustable speed
Linear/Equal% Valve Flow Curve Selection	Yes
Actuator Speed s/mm 60Hz (50 Hz)	3 or 6 (3 or 6)
Power Consumption	15 VA
Operating Temperature Limits °F (°C)	32...131 (0...55)
Actuator Weight (lb.)	16.53
Regulatory Compliance	cULus according to UL 60730-1A/-2-14 and CAN/CSA E60730-1/-2-14 and CE according to EN 60730-1/-2-14 per EMC [2014/30/EU] and LVD [2014/35/EU]
Specification Data Sheet	F-27971
Installation Data sheet	F-27958

a. When used with a proportional input signal.
All actuators are 24 Vac. 50/60 HZ with conduit connector holes and wiring terminal block, manual override.

Table 11. Application: Operation of PIBCV Valve Body Without Actuator

Operation of the PIBCV valve body without an actuator for an automatic flow limiting balancing application.

PIBCV Valve Size	Valve Body Series	Valve Stem Lock Part Number	Recommended Installation and Valve Shut Off Capability
1/2”...1-1/4”	VP228E-xxxxxxx, VP229E-xxxxxxx	Use black cap provided with VP228E-xxxxxxx or VP229E-xxxxxxx valve body	Install valve in the supply water pipe for best shutoff valve performance. To shutoff valve tighten black cap (max. close off pressure is 14.5 psi). To shut off against a higher differential pressure set the valve flow to 0%.
1-1/2”, 2”	VP220E-xxxxx	9114070000 (not included with valve body)	Install valve in either the supply or return water pipe. To shutoff valve tighten bottom knob (max. close off pressure is 232 psi)
2-1/2”...4”	VP220A-xxxxx		Install valve in either the supply or return water pipe. To shutoff valve tighten bottom insert with a 8 mm allen wrench (max. close off pressure is 232 psi)
5”...6”	VP221A-xxxxxx	9114071000 (not included with valve body)	No shut off knob, set the valve to a 0% flow setting to shutoff flow
8”...10”	VP222A-xxxxx	9114072000 (not included with valve body)	

The 9114070000, 9114071000, and 9114072000 Valve Stem Locks are secured to the valve body with a 10 mm allen wrench.
See Table 15. Assembly Valve Body Configurations on page 13 for a listing of all PIBCV valve body part numbers.

Technical Data

Table 12. Specification Threaded Version, 1/2...2"

Valve Size		1/2"				3/4"		1"		1 1/4"		1 1/2"	2"	
Valve Assembly Part Number without PT Ports ¹⁾		VP228E-10LN-	VP228E-15LN-	VP228E-15SN-	VP229E-15HN-	VP228E-20SN-	VP229E-20HN-	VP229E-25SN-	VP229E-25HN-	VP229E-32SN-	VP229E-32HN-	-	-	
Valve Assembly Part Number with PT Ports ¹⁾		VP228E-10L-	VP228E-15L-	VP228E-15S-	-	VP228E-20S-	-	VP229E-25S-	-	VP229E-32S-	-	VP220E-40S-	VP220E-50S-	
Flow range	Q _{min}	.13		.24	.4	1	.8	1.5	1.5	2.4	2.82	3.5	13.2	22
	Q _{nom} (100%) ²⁾	.66		1.2	2	5	4	7.5	7.5	12	14.1	17.5	33	55
	Q _{high}	.79		1.45	2.4	5.5	4.75	8.25	8.2	13.2	15.5	19.25	33	55
Setting range ³⁾		%		20-120%		20-110%	20-120%	20-110%				40-100%		
Diff. pressure ^{4), 5)}	ΔpQ _{nom} (ΔpQ _{high})	psi [kPa]		2.32-58 (2.61-58) [16-400 (18-400)]		5-58 (5.8-58) [35-400 (40-400)]	2.32-58 (2.61-58) [16-400 (40-400)]	5-58 (5.8-58) [35-400 (40-400)]	2.9-58 (3.63-58) [20-400 (25-400)]	5-58 (5.8-58) [35-400 (40-400)]	2.9-58 (3.63-58) [20-400 (25-400)]	5-58 (5.8-58) [35-400 (40-400)]	4.35-58 [30-400]	
	Stroke Q _{nom}	in. (mm)		0.09 (2.25)		.157 (4)	0.09 (2.25)	.157 (4)	.177 (4.5)				.39 (10)	
Connection	ext. thread (ISO 228/1)	G 1/2 A	G 3/4 A			G 1 A		G 1 1/4 A		G 1 1/2 A		G 2 A	G 2 1/2 A	
	actuators	MP131-24T, MP131-24F, MP131-24MP, MP300-SRU, MP300-SRD										MP500C, MP500C-SRU/SRD, MP500C-SRU/SRD-W		
Body Pressure Rating	psi	EN 12516-2:2004, 250 psi, PN 16												
Leakage acc. to standard IEC 60534		Class 4, max. 0.01% of Q _{nom}						max. 0.05% of Q _{nom}						
Max. close off differential pressure across the valve		232 psi (16 bar)												
Control range		Acc. to standard IEC 60534 control range is high as flow characteristic is linear (1:1000)												
Control valve's characteristic		Stem up open, Linear (can be converted by actuator to equal percentage)												
For shut off function		Acc. to ISO 5208 class A - no visible leakage												
Flow medium		Water and water mixture for closed heating and cooling systems according to plant type I for DIN EN 14868. When used in plant Type II for DIN EN 14868 appropriate protective measures are taken. The requirements of VDI 2035, part 1 + 2 are observed.												
Medium temperature	°F (°C)	(water/glycol) 15...250 (-10 ... +120)												
Materials in the water/glycol														
Valve bodies	Dezincification Resistant Brass (CuZn36Pb2As - CW 602N) per EN 12420											Grey iron EN-GJL-250 (GG 25) per EN 1561		
Cone (Pc)	Stainless Steel, W.Nr. 1.4305											Wrought copper CuZn40Pb3-CW 614N, Stainless Steel, W.Nr. 1.4305		
Seat (Pc)	EPDM											Stainless Steel, W.Nr. 1.4305		
Seat (Cv)	Dezincification Resistant Brass (CuZn36Pb2As - CW 602N)											Stainless Steel, W.Nr. 1.4305		
Membranes and O-rings	EPDM													
Springs	Stainless Steel, W.Nr. 1.4568, W.Nr. 1.4310													
Cone (Cv)	Wrought copper, CuZn40Pb3 - CW 614N													
Screw	Stainless Steel (A2)													
Flat gasket	NBR													
Sealing agent (only for valves with PT Ports)	Dimethacrylate Ester													
Materials out of the water/glycol														
Plastic parts	PA											POM		
Insert parts and outer screws	CuZn39Pd3 - CW614N											-		

Note: Water/glycol Compatibility: It is the responsibility of the installer or product specifier to verify water/glycol compatibility of the valves construction materials with the supplier of water/glycol treatment/heat transfer solution.

- 1) See Table 15. Assembly Valve Body Configurations on page 13 for a listing of all PIBCV valve body part numbers.
 - 2) Factory setting of the valve is done at Q_{nom} (100%) or lower depending on flow rate ordered.
 - 3) Regardless of the setting, the valve can modulate below 1% of set flow.
 - 4) Δp = (P1-P3) min-max
 - 5) 87 psi Δp is possible if consideration has been made to the flow velocity, cavitation and noise. For application usage please speak with Product Support
- Pc - Pressure controller
Cv - Control valve

Table 13. Specification Flange Version, 2½"...4"

Valve Size			2½"		3"		4"	
Part Number			VP220A-65S	VP220A-65H	VP220A-80S	VP220A-80H	VP220A-100S	VP220A-100H
Flow range	Q _{min}	gal/min	34	44	48	70	66	104
	Q _{nom} (100%) ¹⁾		85	110	120	176	165	260
Setting range ²⁾		%	40-100%					
Diff. pressure ^{3), 4)}	ΔpQ _{nom}	psi [kPa]	4.35-58 [30-400]	8.7-58 (60-400)	4.35-58 (30-400)	8.7-58 (60-400)	4.35-58 (30-400)	8.7-58 (60-400)
Body Pressure Rating psi			Class 125 per ASME B16.1-2010 Material Class B per ASTM A 126-04 (2014), 200 psi to 150°F, 190 psi to 200°F, 180 psi to 225°F, 175 psi to 250°F					
Control valve's characteristic			Stem up open, Linear (can be converted by actuator to equal percentage)					
Leakage acc. to standard IEC 60534			Max. 0.05% of Q _{nom}					
Max. close off differential pressure across the valve			232 psi (16 bar)					
For shut off function			Acc. to ISO 5208 class A - no visible leakage					
Flow medium			Water and water mixture for closed heating and cooling systems according to plant type I for DIN EN 14868. When used in plant Type II for DIN EN 14868 appropriate protective measures are taken. The requirements of VDI 2035, part 1 + 2 are observed.					
Medium temperature		°F (°C)	(water/glycol) 15...250 (-10 ... +120)					
Stroke Q _{nom}		in. (mm)	.59 (15)					
Connection	flange		ANSI Class 125					
	actuators		MP500C, MP500C-SRU, MP500C-SRD, MP500C-SRU-W, MP500C-SRD-W					
Materials in the water/glycol								
Valve bodies			Grey iron EN-GJL-250(GG25)					
Membranes / Bellow / O-rings			EPDM					
Springs			Stainless Steel, W.Nr. 1.4568, W.Nr. 1.4310					
Cone (Pc)			Wrought copper, CuZn40Pb3 - CW 614N, Stainless Steel, W.Nr. 1.4305					
Seat (Pc) / Seat (Cv)			W.Nr. 1.4305					
Cone (Cv)			CuZn40Pb3 - CW 614N					
Screw			Stainless Steel (A2)					
Flat gasket			NBR					

Table 14. Specification Flange Version, 5"...10"

Valve Size			5"		6"		8"		10"		
Part Number			VP220A-125S	VP220A-125H	VP220A-150S	VP220A-150H	VP222A-200S	VP222A-200H	VP222A-250S	VP222A-250H	
Flow range	Q _{min}	gal / min	158	194	256	332	352	475	528	652	
	Q _{nom} (100%) ¹⁾		395	485	640	830	880	1188	1320	1630	
Setting range ²⁾		%	40-110%								
Diff. pressure ³⁾	ΔpQ _{nom}	psi [kPa]	5.8-58 [40-400]	8.7-58 [60-400]	5.8-58 [40-400]	8.7-58 [60-400]	5.8-58 [40-400]	8.7-58 [60-400]	5.8-58 [40-400]	8.7-58 [60-400]	
Leakage acc. to standard IEC 60534			Class 4, max. 0.01% of Q _{nom}								
Max. close off differential pressure across the valve			232 psi (16 bar)								
Connection	flange		ANSI Class 125				EN 1092				
	actuators		MP2000-NSR, MP2000-SRU, MP2000-SRD				MP4000				
Flow medium			Water and water mixture for closed heating and cooling systems according to plant type I for DIN EN 14868. When used in plant Type II for DIN EN 14868 appropriate protective measures are taken. The requirements of VDI 2035, part 1 + 2 are observed.								
Body Pressure Rating psi			Class 125 per ASME B16.1-2010 Material Class B per ASTM A 126-04 (2014), 200 psi to 150°F, 190 psi to 200°F, 180 psi to 225°F, 175 psi to 250°F								
Control range			Acc. to standard IEC 60534 control range is high as flow characteristic is linear.								
Control valve's characteristic			Stem up open, Linear (could be converted by actuator to equal percentage)								
Medium temperature		°F (°C)	(water/glycol) 15...250 (-10 ... +120)								
Stroke (Q _{nom})		in. (mm)	1.18 (30)								
Materials in the water/glycol											
Valve bodies			Grey iron EN-GJL-250 (GG 25)								
Membranes/ Bellow / O-Rings			W.Nr.1.4571				EPDM				
Springs			Stainless Steel, W.Nr.1.4401				Stainless Steel, W.Nr.1.4310				
Cone (Pc) / Cone (Cv)			Stainless Steel, W.Nr.1.4404NC				Stainless Steel, W.Nr.1.4021				
Flat gasket			Graphite gasket				Non asbestos				
Seat (Pc) / Seat (Cv)			Stainless Steel, W.Nr.1.4027								
Screw			Stainless Steel, W.Nr.1.1181								

1) Factory setting of the valve is done at Q_{nom} (100%) or lower depending on flow rate ordered.

Pc - Pressure controller

2) Regardless of the setting, the valve can modulate below 1% of set flow.

Cv - Control valve

3) Δp = (P1-P3) min-max

4) 87 psi Δp is possible if consideration has been made to the flow velocity, cavitation and noise. for application usage please speak with Product Support

Table 15. Assembly Valve Body Configurations

Pipe Size (in.)	Valve Assembly Part Number Series	Complete Valve Body Part Number	Valve Type	Female NPT End Connectors (included with all 1/2" through 2" Valve Actuator Assemblies)	PT Ports	Installation Data Sheet
1/2	VP228E-10LN-	VP228E-10BQLNT	Threaded	911 2108 010		F-27937
1/2	VP228E-10L-	VP228E-10BQL	Threaded	911 2108 010	Yes	
1/2	VP228E-15LN-	VP228E-15BQLNT	Threaded	911 2108 015		
1/2	VP228E-15L-	VP228E-15BQL	Threaded	911 2108 015	Yes	
1/2	VP228E-15SN-	VP228E-15BQSNT	Threaded	911 2108 015		
1/2	VP228E-15S-	VP228E-15BQS	Threaded	911 2108 015	Yes	
1/2	VP229E-15HN-	VP229E-15BQHNT	Threaded	911 2108 015		
3/4	VP228E-20SN-	VP228E-20BQSNT	Threaded	911 2108 020		
3/4	VP228E-20S-	VP228E-20BQS	Threaded	911 2108 020	Yes	
3/4	VP229E-20HN-	VP229E-20BQHNT	Threaded	911 2108 020		
1	VP229E-25SN-	VP229E-25BQSNT	Threaded	911 2108 025		
1	VP229E-25S-	VP229E-25BQS	Threaded	911 2108 025	Yes	
1	VP229E-25HN-	VP229E-25BQHNT	Threaded	911 2108 025		
1-1/4	VP229E-32SN-	VP229E-32BQSNT	Threaded	911 2108 032		
1-1/4	VP229E-32S-	VP229E-32BQS	Threaded	911 2108 032	Yes	
1-1/4	VP229E-32HN-	VP229E-32BQHNT	Threaded	911 2108 032		
1-1/2	VP220E-40S-	VP220E-40CQS	Threaded	911 2108 040	Yes	F-27934
2	VP220E-50S-	VP220E-50CQS	Threaded	911 2108 050	Yes	
2-1/2	VP220A-65S-	VP220A-65CQS	Flanged		Yes	
2-1/2	VP220A-65H	VP220A-65CQH	Flanged		Yes	
3	VP220A-80S-	VP220A-80CQS	Flanged		Yes	
3	VP220A-80H	VP220A-80CQH	Flanged		Yes	
4	VP220A-100S-	VP220A-100CQS	Flanged		Yes	
4	VP220A-100H	VP220A-100CQH	Flanged		Yes	
5	VP220A-125S-	VP221A-125CQS	Flanged		Yes	
5	VP220A-125H-	VP221A-125CQH	Flanged		Yes	
6	VP220A-150S-	VP221A-150CQS	Flanged		Yes	F-27939
6	VP220A-150H-	VP221A-150CQH	Flanged		Yes	
8	VP222A-200S-	VP222A-200CQS	Flanged		Yes	
8	VP222A-200H-	VP222A-200CQH	Flanged		Yes	
10	VP222A-250S-	VP222A-250CQS	Flanged		Yes	
10	VP222A-250H-	VP222A-250CQH	Flanged		Yes	

Table 16. Selection: Valve Actuator Codes

Actuator Part Number	Actuator Code	Valve Sizes	Non Spring Return	Spring Return Open	Spring Return Close
MP131-24T	A101	½"...1¼"	√		
MP131-24F	F101				
MP131-24MP	S101				
MP300-SRU	U201			√	
MP300-SRD	U301				√
MP500C	U131	1½"...4"	√		
MP500C-SRU	U231			√	
MP500C-SRD	U331				√
MP500C-SRU-W	U234			√	
MP500C-SRD-W	U334				√
MP2000-NSR	U161	5" and 6"	√		
MP2000-SRU	U261			√	
MP2000-SRD	U361				√
MP4000	U181	8" and 10"	√		

Table 17. Selection: ½"...2" Valve Body Tail Pieces

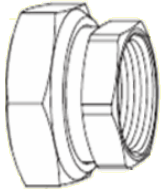
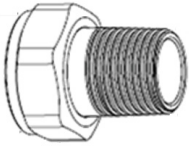
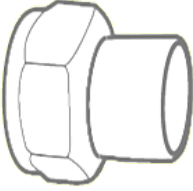
	Part Number	Pipe Size	(A) Approximate Length inches (mm)	Approximate Nut Size inches (mm)	(B) Approximate Valve Body Thread Engagement inches (mm)	Comments	Image
Female NPT Two Female NPT Connectors, Two Gaskets	911 2108 010	1/2"	1.1 (28)	0.99 (25)	0.29 (7.2)	For VP228E-10BQLNT and VP228E-10BQL 1/2" valve bodies only	
	911 2108 015	1/2"	1.1 (28)	1.19 (30.2)	0.29 (7.2)	For all 1/2" valve bodies except VP228E-10BQLNT and VP228E-10BQL	
	911 2108 020	3/4"	1.26 (32)	1.46 (37)	0.33 (8.4)	For all 3/4" valve bodies	
	911 2108 025	1"	1.5 (38)	1.81 (45.8)	0.41 (10.4)	For all 1" valve bodies	
	911 2108 032	1-1/4"	1.65 (42)	2.05 (52.1)	0.42 (10.7)	For all 1-1/4" valve bodies	
	911 2108 040	1-1/2"	1.85 (47)	2.52 (63.9)	0.55 (14)	For 1-1/2" valve body	
	911 2108 050	2"	1.93 (49)	3.24 (82.2)	0.69 (17.5)	For 2" valve body	
Male NPT Two Male NPT Connectors, Two Nuts, Two Gaskets	911 2110 010	3/8"	1.24 (31.5)	0.99 (25)	0.29 (7.2)	For VP228E-10BQLNT and VP228E-10BQL 1/2" valve bodies only	
	911 2110 015	1/2"	1.32 (33.5)	1.19 (30.2)	0.29 (7.2)	For all 1/2" valve bodies except VP228E-10BQLNT and VP228E-10BQL	
	911 2110 020	3/4"	1.5 (38)	1.46 (37)	0.33 (8.4)	For all 3/4" valve bodies	
	911 2110 025	1"	1.73 (44)	1.81 (45.8)	0.41 (10.4)	For all 1" valve bodies	
	911 2110 032	1-1/4"	1.85 (47)	2.05 (52.1)	0.42 (10.7)	For all 1-1/4" valve bodies	
	911 2110 040	1-1/2"	2.28 (58)	2.52 (63.9)	0.55 (14)	For 1-1/2" valve body	
	911 2110 050	2"	2.81 (71.5)	3.24 (82.2)	0.69 (17.5)	For 2" valve body	
Female Sweat Two Female Sweat Ends, Two Nuts, Two Gaskets	911 2109 010	3/8" Tubing (with 1/2" OD)	1.06 (27)	0.99 (25)	0.29 (7.2)	For VP228E-10BQLNT and VP228E-10BQL 1/2" valve bodies only	
	911 2109 015	1/2" Tubing (with 5/8" OD)	1.32 (33.5)	1.19 (30.2)	0.29 (7.2)	For all 1/2" valve bodies except VP228E-10BQLNT and VP228E-10BQL	
	911 2109 020	3/4" Tubing (with 7/8" OD)	1.5 (38)	1.46 (37)	0.33 (8.4)	For all 3/4" valve bodies	
	911 2109 025	1" Tubing (with 1-1/8" OD)	1.73 (44)	1.81 (45.8)	0.41 (10.4)	For all 1" valve bodies	
	911 2109 032	1-1/4" Tubing (with 1-3/8" OD)	1.85 (47)	2.05 (52.1)	0.42 (10.7)	For all 1-1/4" valve bodies	
	911 2109 040	1-1/2" Tubing (with 1-5/8" OD)	2.36 (60)	2.52 (63.9)	0.55 (14)	For 1-1/2" valve body	
	911 2109 050	2" Tubing (with 2-1/8" OD)	2.81 (71.5)	3.24 (82.2)	0.69 (17.5)	For 2" valve body	

Dimensions

Threaded Valves 1/2 to 1 1/4" (inches)

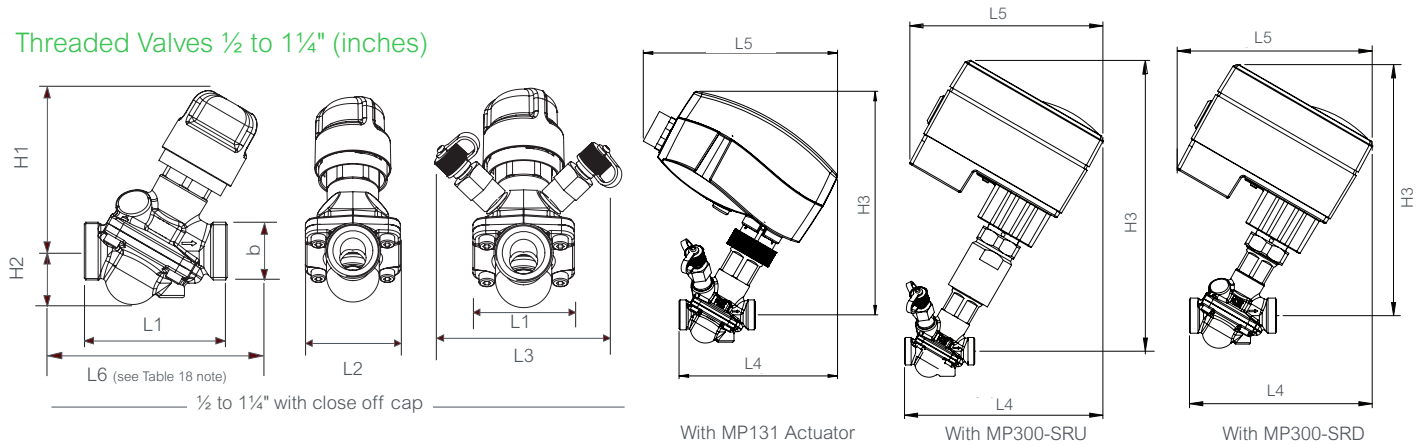

Table 18. Threaded Valves 1/2 to 1 1/4" (inches)

Type	L1	L2	L3 (PLUGS)	L4			L5		H1	H2	H3		b ISO 228/1	Valve Body Weight (lb.)
				MP131	MP300 -SRU	MP300 -SRD	MP131	MP300 -SRU/SRD			MP131	MP300 -SRU/SRD		
1/2" VP228E-10Lx	2	1.41	3.11	4.37	5.11	5.90	5.35	5.7	2.9	.78	5.6	7.2	G 1/2	.83
1/2"	2.5	1.7		4.64	5.39	6.14			3	1	5.7	7.4	G 3/4	1
3/4"	3.2	2.2		4.96	5.7	6.53			3	1.2	5.8	7.5	G 1	1.43
1"	4	2.7		5.55	6.3	7.08			3.5	1.5	6.14	7.83	G 1 1/4	3.2
1 1/4"	5.1	3.5		6.26	7	7.8			3.9	2.3	6.58	8.27	G 1 1/2	4.8

NOTE: Valve Body Tail Piece Dimensions: See Columns A and B in Table 17 on page 14. For assemblies with Female NPT: L6= (2x Column A - 2x Column B) +L1

Threaded Valves 1 1/2" and 2" (inches)

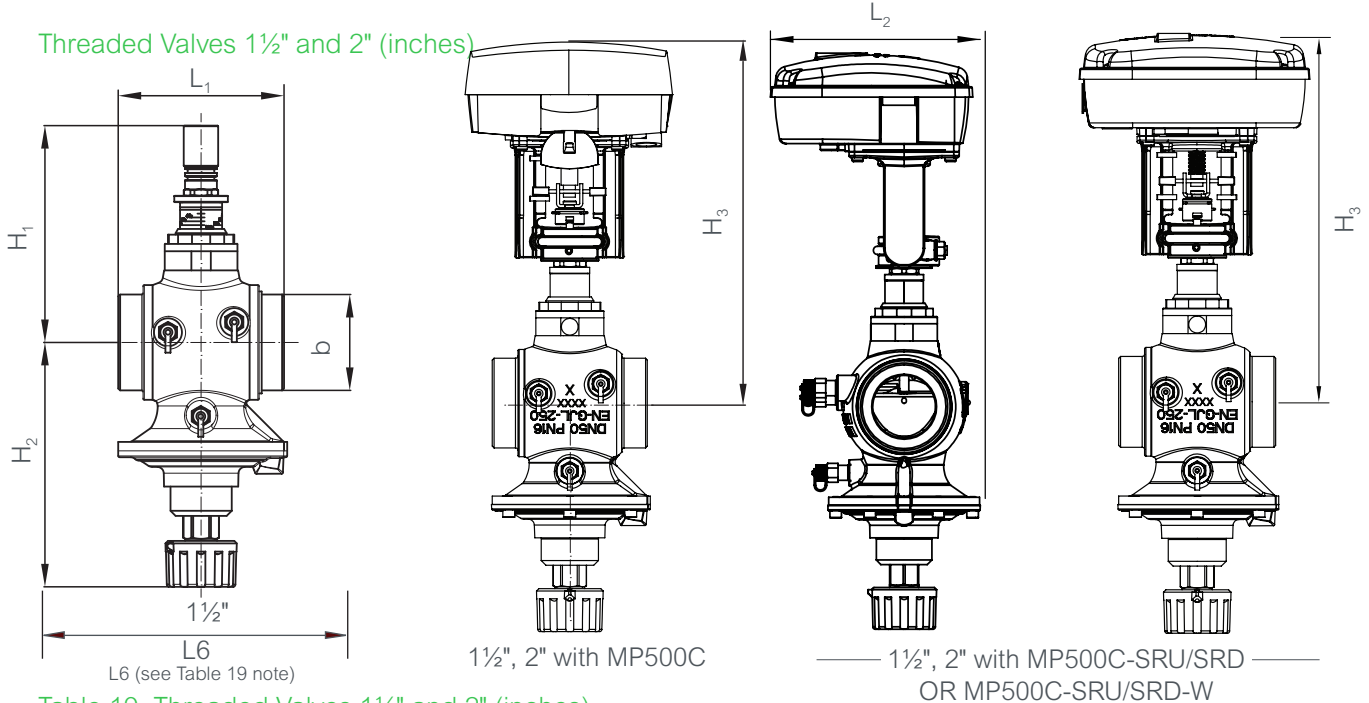

Table 19. Threaded Valves 1 1/2" and 2" (inches)

Type	L ₁	L ₂	H ₁	H ₂	H ₃	b ISO 228/1	Valve Body Weight lb
1 1/2"	4.33	7.19	6.7	6.85	11	G 2	15.8
2"	5.11					G 2 1/2	18.0

NOTE: Valve Body Tail Piece Dimensions: See Columns A and B in Table 17 on page 14. For assemblies with Female NPT: L6= (2x Column A - 2x Column B) +L1

Table 20. Flanged Valves 2½"…4" (inches)

Type	L ₁	L ₂	H ₁	H ₂	H ₃	a (EN 1092-2)	Valve Body Weight (lb)	No. of Flange Bolt Holes
2½"	11.4	8.76	8.6	6.77	13	7.2	84	4
3"	12.2	8.88	8.9	6.96	13.1	7.87	99	4
4"	13.7	10.07	9.44	7.36	13.7	8.66	126	8

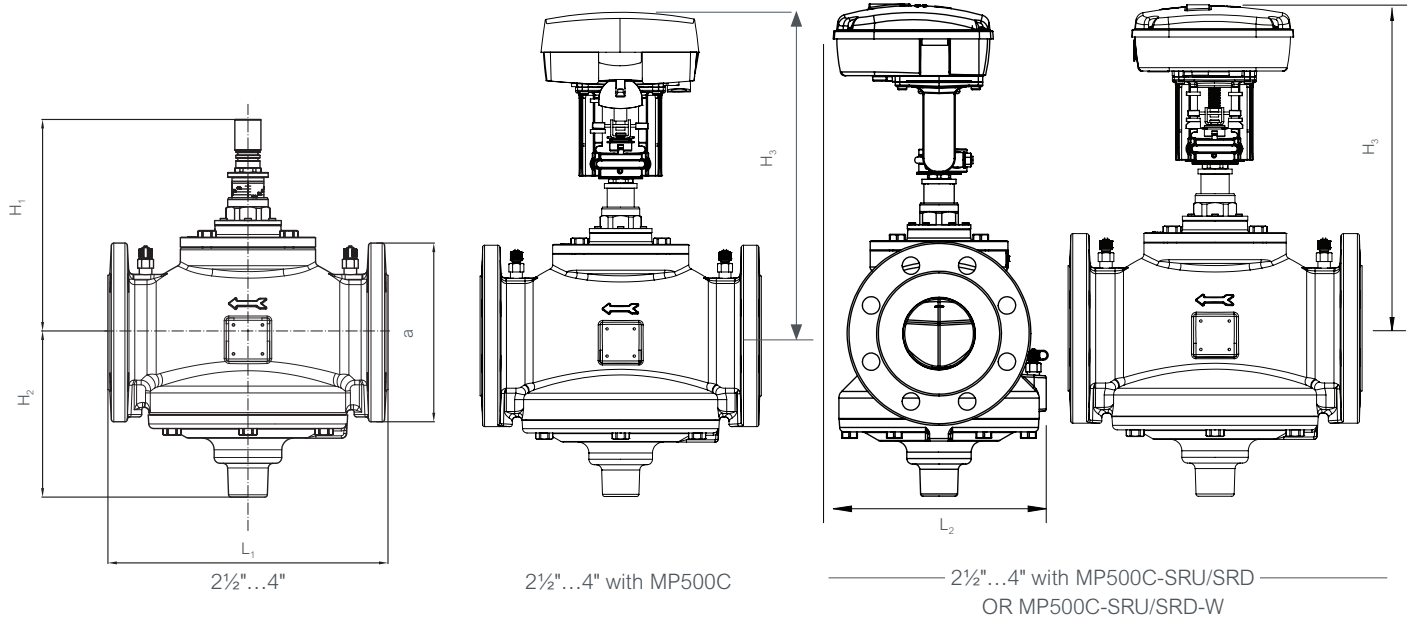

Flanged Valves 5" and 6"

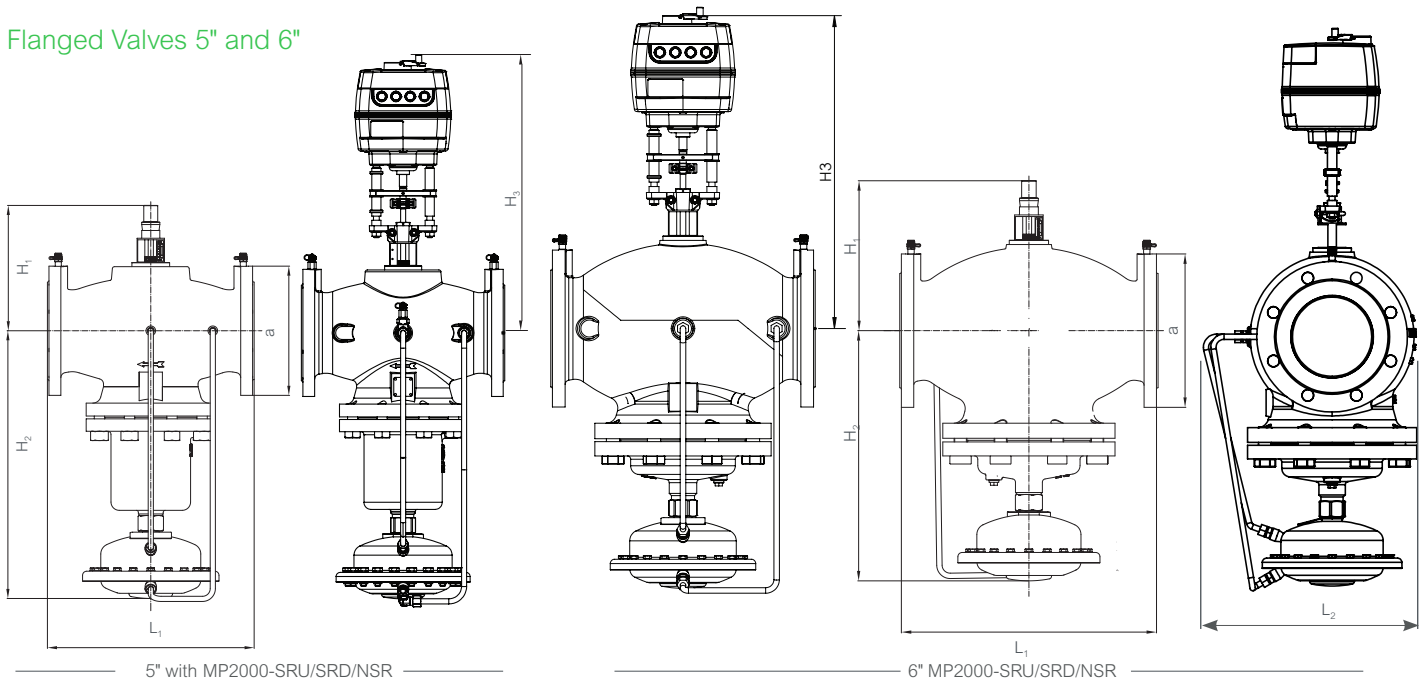

Table 21. Flanged Valves 5" and 6" (inches)

Type	L ₁	L ₂	H ₁	H ₂	H ₃ MP2000-SRU/SRD/ NSR	a (EN 1092-2)	Valve Body Weight (lb.)	No. of Flange Bolt Holes
5"	15.7	14.45	10.7	21.1	20.94	9.84	188	8
6"	18.9	15.88	12.1	19.6	22.36	11.22	304	8

Flanged Valves 8" and 10"

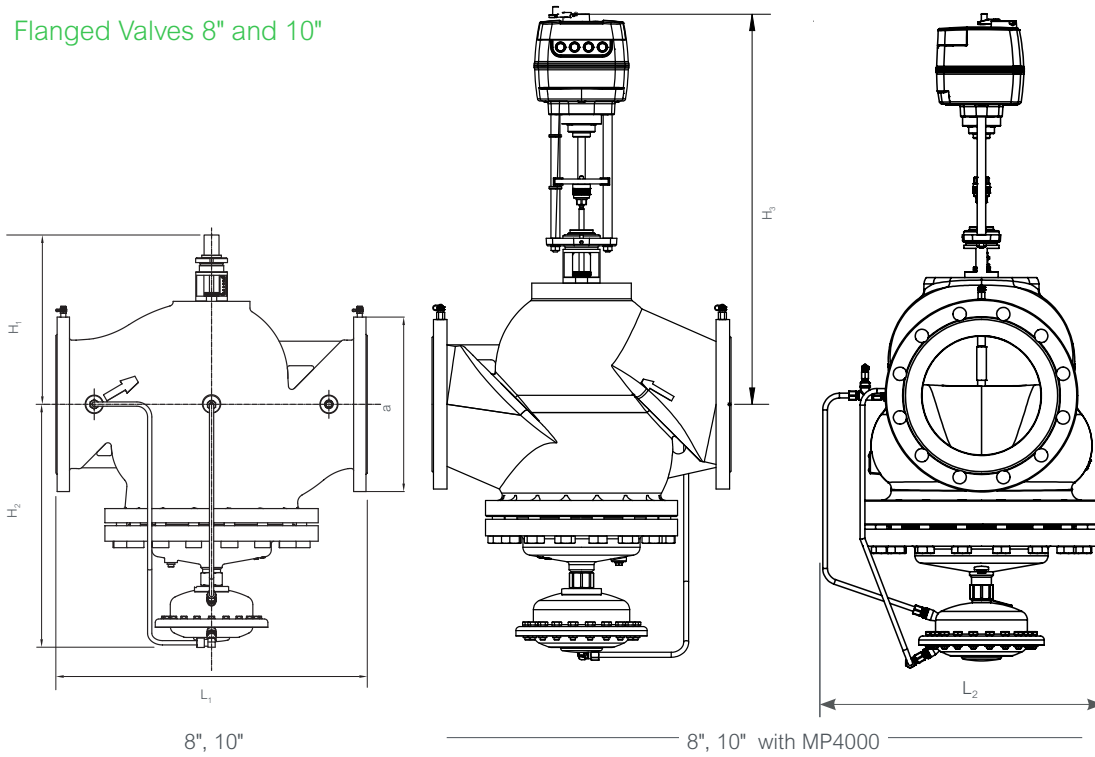
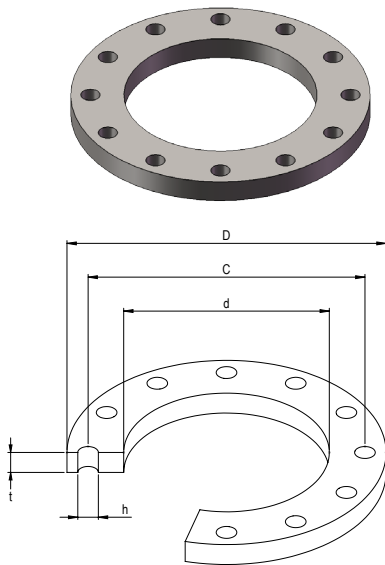

Table 22a. Flanged Valves 8" and 10" (inches)

See Table 22b for Valve Flange Adapters.

Type	L ₁	L ₂	H ₁	H ₂	H ₃ MP4000	a (EN 1092-2)	Valve Body Weight (lb.)	No. of Flange Bolt Holes
8"	23.6	19.57	17.0	19.0	24.3	13.38	482	12
10"	28.7	22.98	16.9	20.9	27.8	15.9	753	12

Table 22b. Valve Flange Adapters 8" and 10"



Specifications and Part Numbers		
Size	8" (200 mm)	10" (250mm)
Part Number	D2576-16-200	D2576-16-250
Bolt Hole Diameter	.87" (22 mm)	1.02" (25.9 mm)
Bolt Circle	11.61" (294.89 mm)	13.98" (355.09 mm)
Pressure	PN16	
d	8.63" (219.1 mm)	10.75" (273mm)
D	13.39" (340 mm)	15.94" (405mm)
C	11.61" (295 mm)	13.98" (355mm)
Number of Bolts	12	
h	0.87" (22 mm)	1.02" (26mm)
t	1.024" (26 mm)	1.14" (29mm)
Weight	24.03 lbs (10.9 kg)	39.68 lbs (18.0 kg)
Material	Carbon Steel	Carbon Steel
IMPA/ISSA Code	734554 735564	734555 735565

Note: Two Flange Adapters are shipped with each 8" and 10" Valve Body and Valve Assembly

Table 23. ½...2" Valve Flow Ranges (Q_{min} to Q_{nom})

Flow Rate (GPM)	1/2"				3/4"		1"		1¼"		1½"	2"
Without PT Ports	VP228E-10BQLNT	VP228E-15BQLNT	VP228E-15BQSNT	VP229E-15BQHNT	VP228E-20BQSNT	VP229E-20BQHNT	VP229E-25BQSNT	VP229E-25BQHNT	VP229E-32BQSNT	VP229E-32BQHNT	-	-
With PT Ports	VP228E-10BQL	VP228E-15BQL	VP228E-15BQS	-	VP228E-20BQS	-	VP229E-25BQS	-	VP229E-32BQS	-	VP220E-40CQS	VP220E-50CQS
0.5	1	1	1									
1.0		1	1	1	1							
1.5			1	1	1	1	1					
2.0			1	1	1	1	1					
2.5				1	1	1	1	1				
3.0				1	1	1	1	1	1			
3.5				1	1	1	1	1	1	1		
4.0				1	1	1	1	1	1	1		
4.5				1	(1)	1	1	1	1	1		
5.0				1		1	1	1	1	1		
5.5				(1)		1	1	1	1	1		
6.0						1	1	1	1	1		
6.5						1	1	1	1	1		
7.0						1	1	1	1	1		
7.5						1	1	1	1	1		
8.0						(1)	(1)	1	1	1		
8.5								1	1	1		
9.0								1	1	1		
9.5								1	1	1		
10								1	1	1		
11								1	1	1		
12								1	1	1		
13								(1)	1	1	1	
14									1	1	1	
15									(1)	1	1	
16										1	1	
17										1	1	
18										(1)	1	
19										(1)	1	
20											1	
21											1	
22											1	1
23											1	1
24											1	1
25											1	1
26											1	1
27											1	1
28											1	1
29											1	1
30											1	1
31											1	1
32											1	1
33											1	1
34												1
35												1
36												1
37												1
38												1
39												1
40												1
44												1
48												1
52												1
55												1

(Q_{high} setting)

All flanged valves come standard with PT ports

Table 24. 2½" ... 10" Flanged Valve Flow Ranges (Q_{min} to Q_{nom})

Size	2-1/2"		3"		4"		5"		6"		8"		10"	
Flow Rate (GPM)	VP220A-65CQS	VP220A-65CQH	VP220A-80CQS	VP220A-80CQH	VP220A-100CQS	VP220A-100CQH	VP221A-125CQS	VP221A-125CQH	VP221A-150CQS	VP221A-150CQH	VP222A-200CQS	VP222A-200CQH	VP222A-250CQS	VP222A-250CQH
35	34													
40	1													
45	1	44												
50	1	1	48											
55	1	1	1											
60	1	1	1											
65	1	1	1											
70	1	1	1	70	66									
75	1	1	1	1	1									
80	1	1	1	1	1									
85	85	1	1	1	1									
90		1	1	1	1									
95		1	1	1	1									
100		110	1	1	1	104								
120			120	1	1	1								
140				1	1	1								
160				176	165	1	158							
180						1	1							
200						1	1	194						
250						260	1	1						
300							1	1	256					
350							1	1	1	332	352			
400							395	1	1	1	1			
450								485	1	1	1	475		
500									1	1	1	1	528	
550									1	1	1	1	1	
600									640	1	1	1	1	
650										1	1	1	1	652
700										1	1	1	1	1
750										1	1	1	1	1
800										830	880	1	1	1
850												1	1	1
900												1	1	1
950												1	1	1
1000												1	1	1
1100												1188	1	1
1200													1320	1
1300														1
1400														1
1500														1
1600														1630
1700														

All flanged valves come standard with the PT ports

Specification Submittal Text

SpaceLogic PIBCV has the following specifications:

- NPS 2 and Smaller: PN 16, stainless steel components.
- NPS 2-1/2 through 10: Class 125 cast iron body per ASME B16.1-2010, Material class B per ASTM A 126-04 (2014), stainless steel components.
- Accuracy NPS ¾ and Smaller: The control valves shall accurately control the flow from 0 to 100% rated flow with a differential pressure range of 2.32 to 58 psi for low and standard flow units, 5 to 58 psi for high flow units within 5% of set flow value.
- Accuracy NPS 1 through 1-1/4: The control valves shall accurately control the flow from 0 to 100% rated flow with a differential pressure range of 2.9 to 58 psi for standard flow units, 5 to 58 psi for high flow units within 5% of set flow value.
- Accuracy NPS 1-1/2 through 4: The control valves shall accurately control the flow from 0 to 100% rated flow with a differential pressure range of 4.35 to 58 psi for standard flow units, 8.7 to 58 psi for high flow units within 5% of set flow rate.
- Accuracy NPS 5 through 10: The control valves shall accurately control the flow from 0 to 100% rated flow with a differential pressure range of 5.8 to 58 psi for standard flow units, 8.7 to 58 psi for high flow units within 5% of set flow value.
- Flow Characteristics: Linear Control, selectable to equal percentage at the proportional valve actuator.
- Field adjustable flow by means of a percentage of rated valve flow.
- Position feedback output signal integrated into all proportional actuators.
- 100% authority with modulating below 1% regardless of flow settings.
- No cartridges requiring replacement or maintenance.
- Close off ratings shall be 232 psi for all valve sizes.
- Valve control range 1:1000.

