

SpaceLogic MP130-24MP

Modulating Actuators with Position Feedback
For VP228E/VP229E PIBCV, DN10...32



Product Description

The MP130-24MP is a position feedback actuator for the **SpaceLogic** PIBCV DN10...DN32 pressure independant balance and control valves. This actuator can be used with fan coil units, induction units, small reheaters, recoolers and zone applications in which hot/cold water is the controlled medium.

Features

- Gap detection at stem up position for accurate stroke calibration to any flow setting
- Modulating control with low hysteresis
- Force switch-off at stem down position prevents overload of actuator and valve
- No tools required for mounting
- Maintenance-free lifetime
- Low-noise operation
- Self-positioning process
- Halogen free cables

Specifications

Power supply	24 Vac, +20...-15 %
Power consumption	
running	1.5 VA
standby	.4 W
Control input Y	0...10 (2...10) Vdc, 200 kΩ 0...20 (4...20) mA, 500 kΩ
Position output X	0...10V, min 38 kΩ
Frequency	50/60 Hz
Close off force	130 N
Stroke	5 mm
Speed	24 s/mm
Relative humidity	max. 80 %
Max. medium temperature	120 °C
Ambient temperature	0...55 °C
Storage and transport temp.	-40...70 °C
Protection class	III safety extra-low voltage
Grade of enclosure	IP 42
Weight	0.3 kg
Sound power level	Max. 35 dB(A)
EMC Directive & Standards	2014/30/EU EN 61000-6-2 & EN 61000-6-3
LVD Directive & Standards	2014/35/EU EN 60730-1 & EN 60730-2-14
RoHS2 Directives	2011/65/EU & RoHS2 Amendment 2015/863/EU

Dimensions (mm)

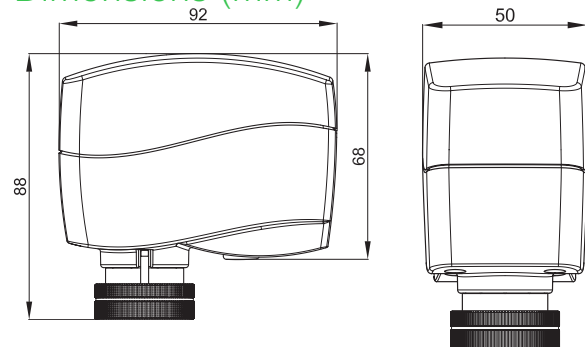

Part Numbers

Part Number	Cable Length (m)
MP130-24MP	1.5
MP130-24MP-10M	10

Mounting and Installation

Check the actuator spindle position before mounting as the spindle should be fully retracted before mounting onto **SpaceLogic** PIBCV valves (see manual override drawings). The actuator can be mounted with the valve stem in either horizontal position or pointing upwards. The actuator is fixed to the valve body by means of a mounting ring (1), which requires no tools for mounting.

It is mandatory to check and if necessary drive the spindle of the actuator to upper position before it will be installed on **SpaceLogic** PIBCV valve (please refer to manual override drawings).

Procedure:

1. Check the valve neck. The actuator should be in stem up (retracted) position (factory setting).
2. Mount the actuator onto the valve, tightening the mounting ring by hand only.
3. Wire the actuator according to the wiring diagram.
4. The direction of the stem movement can be observed on the position indicator.

The factory setting of the actuator spindle is the fully retracted stem up position for easier mechanical connection.

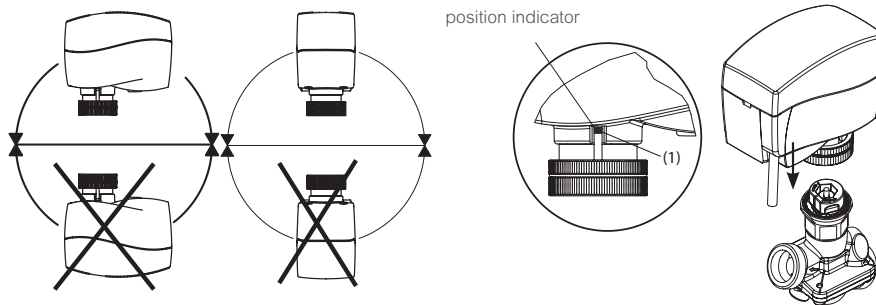

Manual Override

Do not dismantle the actuator from the valve when the valve stem is in the down position as there is a risk this will cause the actuator to seize. When the manual override has been used, the output signal (X) is not correct until the actuator reaches its end position.

Procedure:

1. Remove cover (1) inserting flat screwdrivers heads into the slots and pry off the cover with an upward motion.
2. Press and hold the button (2) on the bottom side of the actuator during manual override (3) twisting of knob.
3. Replace cover (4) and install actuator on valve.

NOTE: A 'click' sound after energising the actuator indicates that the gear wheel has jumped into normal position.

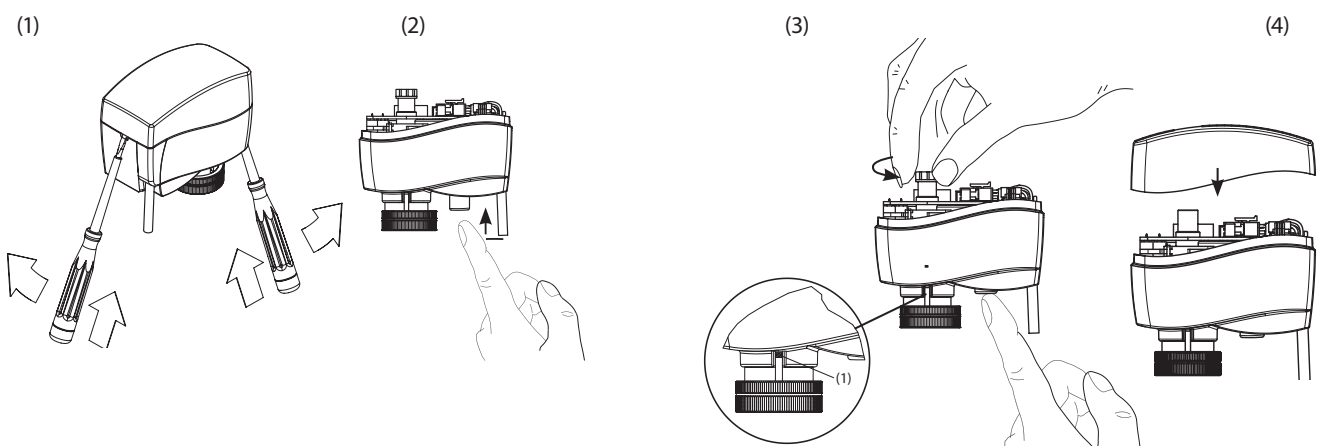

If manual override has been used, the actuator position against the Y signal and also the position feedback signal will not be correct until the actuator has reached its end position. If this is not desired, reset the actuator.

Wiring and Connections

Wire the actuator according to the wiring diagram. Each actuator is supplied with the connecting cable for the controller.

NOTE: It is strongly recommended that the mechanical installation is completed before the electrical installation.

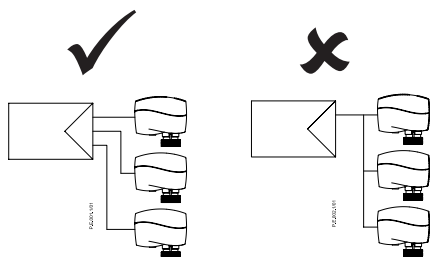

NOTICE

RISK OF EQUIPMENT DAMAGE

- Avoid electrical noise interference.
- Do not install near large contactors, electrical machinery, or welding equipment.
- Only use manual override when power is off.

Failure to follow these instructions may result in damage to the gear train or other mechanical damage.

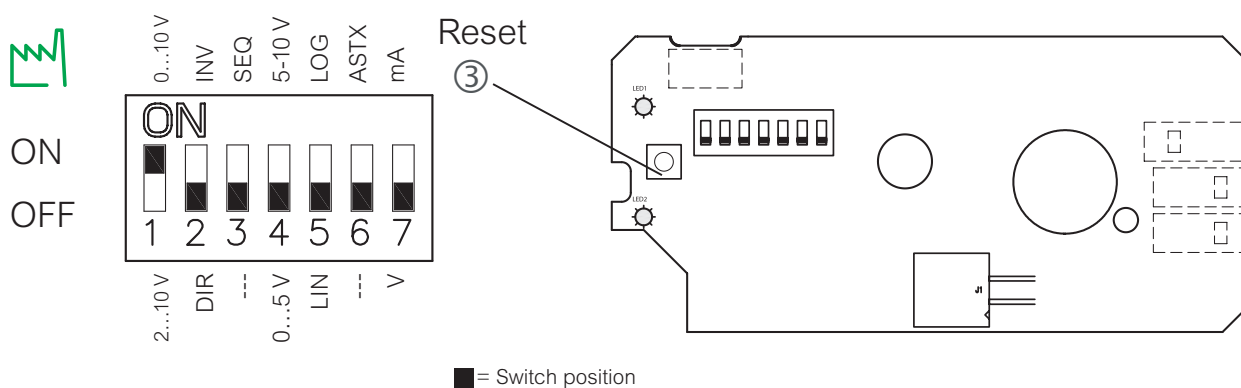

DIP Switch Setting

All switches (except switch 2 which is in ON position) are in OFF positions from factory. DIP switches are located under the removable cover.

Note: When the manual override has been used, the output signal (X) is not correct until the actuator reaches its end position. The actuator has a function selection DIP switch under the removable cover. The switch provides the following functions:

- **SW1: 0/2 - Input signal range selector**
 - If set to OFF position, the input signal is in the range from 2...10 V (voltage input) or from 4...20 mA (current input).
 - If set to ON position, the input signal is in the range from 0...10 V (voltage input) or from 0...20 mA (current input).
- **SW2: D/I - Direct or inverse acting selector**
 - If set to OFF position, the actuator is direct acting (stem lowers as voltage increases).
 - If the actuator is set to ON position, the actuator is inverse acting (stem raises as voltage increases).
- **SW3: ---/Seq - Normal or sequential mode selector:**
 - If set to OFF position, the actuator is working in range 0(2)...10 V or 0(4)...20 mA.
 - If set to ON position, the actuator is working in sequential range; 0(2)...5(6) V or 0(4)...10(12) mA or (5(6)...10 V) or (10(12)...20 mA).

- **SW4: 0...5 V/5...10 V - Input signal range in sequential mode:**
 - If set to OFF position, the actuator is working in sequential range 0(2)...5(6) V or 0(4)...10(12) mA.
 - If set to ON position, the actuator is working in sequential range; 5(6)...10 V or 10(12)...20 mA.
- **SW5: LIN/LOG - Linear or equal percentage flow through valve selector**
 - If set to OFF position, the flow through the valve is equal percentage-wise equals the control signal.
 - If set to ON position, the flow through the valve is linear in accordance to the control signal.
- **SW6: ---/ASTK - Anti-blocking function**
 - Exercises the valve to avoid blocking in periods when the heating/cooling is off.
 - If set to ON position (ASTK), the valve motion is switched on. The actuator opens and closes the valve every 7 days.
 - If set to OFF position (---), the function is disabled.
- **SW7: V/mA - Input signal type selector**
 - If set to OFF position, voltage input is selected. If set to ON position, current input is selected.

NOTE: The reset button ③ will cause the actuator to go through a self stroking cycle (press it for 2 s).

