

# SpaceLogic MG350-24F

## Globe Valve Actuator



### Product Description

The MG350-24F is a compact electro-mechanical actuator for controlling two-way and three-way Venta globe valves V211, V211T, V241, V311, and V311T and V341.

The MG350-24F is a dual, 2 position / 3 point floating actuator within the **SpaceLogic** Actuator family. The MG350 actuators are primarily designed for applications where the demands on speed and thrust are relatively small, such as:

- Mixing and injection heating circuits
- Small air handling systems
- Large Fan coil units

### Features

- High Functionality
  - Stable force control with stall protection
  - Dual 3 Point floating and 2 position control.
  - Sink or source floating control
  - High Resolution PCBA and motor transmission for fine valve plug position and excellent flow control.
- LED status indication
  - Bi-color LED to indicate direction of movement when under power.
- Removable terminal block and cable gland for ease of installation.
- Compact Construction: Optimally designed to fit Venta valves with 20mm Stroke.

### Specifications

Supply voltage	24 Vac/dc $\pm$ 20% 50/60 Hz
Power Consumption (50Hz), full load Running	3.5 W
Transformer sizing	5.2 VA
Running Time	4 s/mm (Full stroke time, Venta Valves = 80 sec)
Max. Stroke	21.5 mm
Force	350 N
Control	Dependant upon wiring, page 3
3 wire Floating	24 Vac/dc or 0V
2 Position on/off	NO or NC
Minimum input pulse	100 msec
Ambient Temperature Range	
Ambient Operational Range	-5...+55°C (for valve fluid temperatures up to 130°C)
Storage temperature Range	-40...+70°C
Ambient humidity	max . 95%
Protection rating	IP 53 (vertically mounted)
Sound power level	max. 30 dBA

Key Materials	
Yoke	Aluminum
Housing	PBT/PC
Standards/Directives	
ElectroMagnetic Compatibility [EMC]	2014/30/EU
Low voltage directive [LVD]	2014/35/EU
Restriction of Hazardous Substances [RoHS2]	2011/65/EC
Heat	IEC 60068-2-2
Humidity	IEC 60068-2-3
Cold	IEC 60068-2-1
Vibration	IEC 60068-2-6
Manual Override	3 mm Hex (T style hand tool recommend)
Position indication	Yoke position indicator with red and blue position markers for hot and cold pipe indication (green position indicator for closed valve)
Cable Gland wire size	2.4 to 6.6 mm
Conduit hole	M20
Weight (shipping)	0.36 kg

## Function

### Actuator

The actuator utilizes a stepper motor to accurately position the main spindle via a gearbox based on the command received from the controller.

### Control Signal

This MG350-24F **SpaceLogic** Actuator series can be controlled either by 3 wire floating (increase/decrease) switched either between the 24 Vac/dc supply or by the 0V return. 2 position control for the actuator to retract or extend (IN/OUT) proving a normally open or normally closed valve is possible by configuring the wiring, see wiring diagrams on page 3.

## Manual Operation

A 3mm hex key can be used to manually drive and position the MG350 **SpaceLogic** Actuator. Do not depress the hex key during normal operation. The hex key is not supplied with the actuator.

The Hex key should be depressed firmly to disengage the main drive motor and continue to be depressed whilst rotating the key to adjust actuator position. It takes approximately 5 full rotations of the manual override to fully stroke the valve, each manual override turn moves the valve stem about 4 mm. There may be a load click as the main drive motor re-engages after a manual operation.

## Maintenance

The actuator is maintenance-free.

## Mounting

### ⚠ WARNING

#### RISK OF BURNS OR FLYING PARTS

If the valve stem, spindle, or plug has been damaged, it may blow out under pressure while servicing the actuator.

- Isolate and depressurize the valve before servicing.
- Manually check valve stem, spindle, or plug integrity by moving it within the valve. If the part can be removed, replace the valve assembly.

**Failure to follow these instructions may result in death or serious injury.**

Mount the actuator horizontally, vertically, or in any position in between, but not upside down. If the media temperature is above 120°C, install the actuator at an angle over the pipe-work to reduce the radiant heat influence.

For water ingress protection, do not mount actuators below the horizontal plane of the valve. IP63 will be achieved with a mounting orientation from vertical to 60 deg. IP51 will be achieved to 85 deg.

## Dimensions (mm)

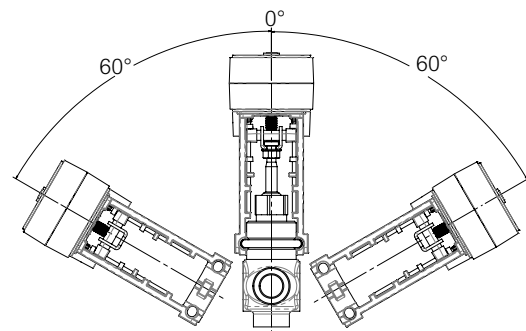
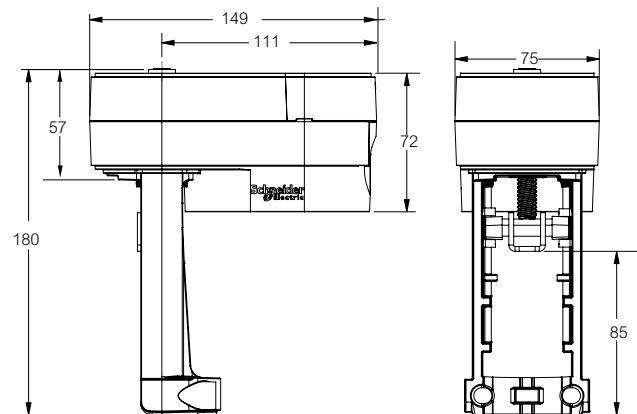

## Mounting the Actuator on the Venta Valve

A square nut is supplied with the actuator and is to be mounted onto the top edge of the valve stem before the actuator is mounted. The actuator is delivered so it is not needed to operate the manual override to assemble the product.

1. Assemble the square nut to the top edge of the valve stem leaving some clearance between this nut and the flanged nut below.
2. Position the valve stem by hand to align with the actuator clasp.
3. Slide the actuator onto the valve neck, aligning the actuator clasp in between the square nut and flanged nut.
4. Push the actuator down to align and insert the U-bolt brace; secure brace with the flanged nuts.
5. Tighten the valve stem flanged nut.

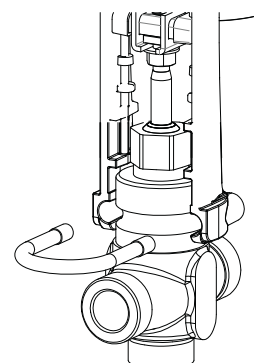

## Colored Valve Limit Indicators

The colored end stop limits on the yoke are provided to show the valve plug position according to the valve stroke. After mounting the actuator, arrange the position and colour of the limits as per the table below, discarding either the red or blue as needed.

Squeeze the end stop limits either side of the actuator cross bar and initiate a calibration sequence, the actuator will then automatically push the end stop limits to the exact limits of

the valve stroke. It is recommended to set-up the colored valve end stop limits according to the valve and media during commissioning.

Position the limits as follows:

Green end stop	Closed valve
Red end stop	Open heating circuit
Blue end stop	Chilled water circuit

## Terminal Block Connection

Y1	24 $\perp$	Y2
Extends the actuator linkage and lowers the valve stem	24 Vac/dc supply for sinking 24 Vac neutral or 24 Vdc common for sourcing	Retracts the actuator linkage and raises the valve stem

**NOTE:** The MG350-24F actuator is powered by Y1 and/or Y2. If both Y1 and Y2 are powered at the same time, then the actuator retracts linkage and raises the stem.

## Wire Sizing

Cable type	Maximum length	Minimum cross sectional area
Power	100 m (328 ft)	1.5 mm <sup>2</sup> (AWG 16)

## Direction of Operation

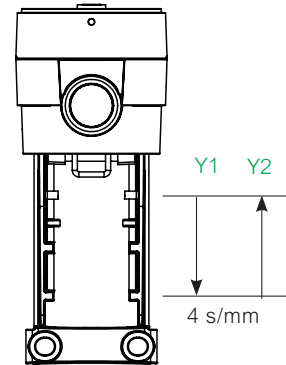

## Wiring

### Three Wire Floating

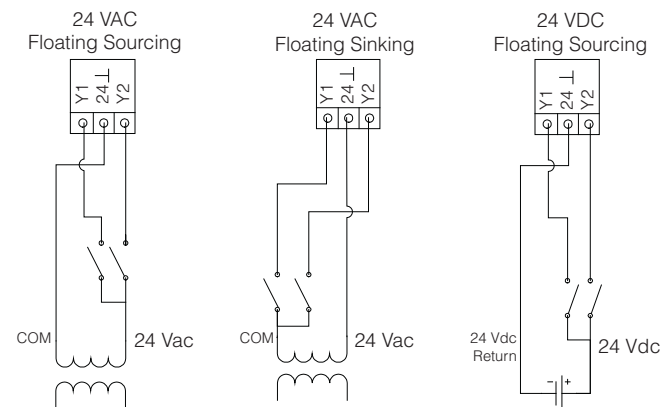

### Two Position (On/Off)

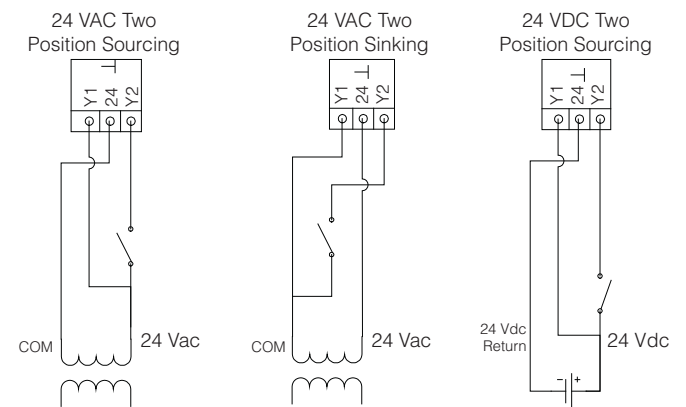

## Normal LED Operation

LED Color	Blinking pattern	Function
Orange	light 0.3 sec, every second	Indicates actuator is extending, lowering the valve stem to open the valve
Green	light 0.3 sec, every second.	Indicates actuator is retracting, lifting the valve stem to close the valve

